

2014

Production of 2-propanol, butanol and ethanol using *Clostridium beijerinckii optonii*

Adam Hoogewind

Louisiana State University and Agricultural and Mechanical College

Follow this and additional works at: https://repository.lsu.edu/gradschool_dissertations



Part of the [Life Sciences Commons](#)

Recommended Citation

Hoogewind, Adam, "Production of 2-propanol, butanol and ethanol using *Clostridium beijerinckii optonii*" (2014). *LSU Doctoral Dissertations*. 3497.

https://repository.lsu.edu/gradschool_dissertations/3497

This Dissertation is brought to you for free and open access by the Graduate School at LSU Scholarly Repository. It has been accepted for inclusion in LSU Doctoral Dissertations by an authorized graduate school editor of LSU Scholarly Repository. For more information, please contact gradetd@lsu.edu.

PRODUCTION OF 2-PROPANOL, BUTANOL AND ETHANOL USING
CLOSTRIDIUM BEIJERINCKII OPTONII

A Dissertation

Submitted to the Graduate Faculty of the
Louisiana State University and
Agricultural and Mechanical College
in partial fulfillment of the
requirements for the degree of
Doctor of Philosophy

in

The Department of Nutrition and Food Sciences

by
Adam Hoogewind
B.S. Aquinas College, 2006
May 2014

ACKNOWLEDGEMENTS

I would like to thank my advisor, Dr. Donal Day for his support and guidance for the past four and a half years. His broad knowledge of microbiology, sugarcane, renewable fuels and government conspiracies has been helpful in the completion of my research.

I would also like to thank the food science professors, Dr. Joan King, Dr. Marlene Janes and Dr. Jack Losso in passing on the knowledge needed in the completion of my degree as well as future endeavors beyond graduate school.

I would like to thank Misook Kim and Young-Hwan Moon for helping with various stages of my research and keeping me company in the lab, as well as the analytical chemists Lee Madsen, Derrek Dorman and Chardcie Verret for helping with the analyses of sugars and solvents.

I would also like to help Dr. Ken Bondioli for his help with the statistical work in my study.

My research would not have been possible without the financial support of Jack Oswald and Optinol™ as well as the grant and stipend from Louisiana State University

TABLE OF CONTENTS

ACKNOWLEDGEMENTS	ii
LIST OF TABLES	v
LIST OF FIGURES	vi
ABSTRACT	x
I. INTRODUCTION	1
II. LITERATURE REVIEW	4
Alternatives to Fossil Fuels	4
Fuel Properties of Butanol and Ethanol	8
<i>Clostridium</i> Genus	9
<i>Clostridium</i> Metabolism	11
Batch Culture	18
Mutagenic Research to Increase Solvent Production	22
Immobilized Culture	25
Coextraction of Butanol	30
III. MATERIALS AND METHODS	33
Microorganism	33
Organism Identification	33
Preparation and Storage of Inocula	33
Growth and Production Conditions	35
Determination of Optimal Growth Temperature	35
Solvent Toxicity	35
Batch Fermentations	35
Butanol Coextraction	36
Immobilized Cell Column	37
Analytical Procedures	37
Statistical and Experimental Design	40
IV. RESULTS	41
Optimization of Temperature	41
Sugar Fermentation Test	42
Solvent Toxicity	43
Growth and Production of Solvents on Glucose [P2 medium] with Varying $\text{FeSO}_4 \cdot 7\text{H}_2\text{O}$ Concentrations	44
Glucose Fermentation with 1.0 mg/L $\text{FeSO}_4 \cdot 7\text{H}_2\text{O}$	44
Glucose Fermentation with 1.5 mg/L $\text{FeSO}_4 \cdot 7\text{H}_2\text{O}$	48
Glucose Fermentation with 2.0 mg/L $\text{FeSO}_4 \cdot 7\text{H}_2\text{O}$	50
Glucose Fermentation with 0.5 mg/L $\text{FeSO}_4 \cdot 7\text{H}_2\text{O}$	55
Glucose Fermentation with 0.5 mg/L $\text{FeSO}_4 \cdot 7\text{H}_2\text{O}$ with Inhibitory pH	59

	Glucose Fermentation with 2.0 mg/L FeSO ₄ ·7H ₂ O with Inhibitory pH ····	64
	Summary of Iron Sulfate Supplementation ·····	66
	Glucose Fermentation with Soy Oil Coextraction ·····	70
	Sugarcane Juice Fermentation ·····	71
	Molasses Fermentation ·····	76
	Summary of Sugarcane Product Fermentations ·····	79
	Immobilized Cell Culture ·····	81
V.	DISCUSSION ·····	90
	<i>C. beijerinckii optonii</i> Classification ·····	90
	Fermentation of Glucose in the Presence of Differing Amounts of FeSO ₄ ·7H ₂ O ··	91
	Explanation of the Acid Crash ·····	92
	Fermentations Using Sugarcane Juice and Sugarcane Molasses ·····	94
	Immobilized Continuous Fermentation ·····	95
	Economics of Butanol Production ·····	97
VI.	SCIENTIFIC CONTRIBUTIONS ·····	101
VII.	FUTURE RESEARCH ADVICE ·····	102
VIII.	REFERENCES ·····	103
IX.	VITA ·····	111

LIST OF TABLES

1. Motor-Related Properties of Alcohols and Gasoline ·····	3
2. Carbon Sources Fermented by Four Major Solventogenic <i>Clostridium</i> Species (from Keis et al, 2011) ·····	12
3. Possible Outcomes of Direct Fermentation of Glucose and the Yields of ATP and Balance of NADH/NAD ⁺ ·····	15
4. Comparison Between RCM, TYA, AnS and P2 Media Containing 30 g/L Glucose and the ABE Fermentation Results Using a Newly Discovered <i>Clostridium</i> Bacteria (from Al-Shorgani et al, 2013) ·····	18
5. Various ABE Fermentation Results ·····	20
6. Various Results from Continuous Fermentations ·····	28
7. Results from Batch Fermentations Using <i>in-situ</i> Product Removal ·····	32
8. Carbon Sources Fermented by <i>C. saccharoperubutylaceticum</i> , <i>C. beijerinckii</i> and achieved results by <i>C. beijerinckii optonii</i> ·····	43
9. Summary of the Effects of Iron on Fermentation ·····	68
10. Percentages of Solvents Formed in Fermentations of Glucose in P2 Media Exhibiting Low Terminal pH and Normal pH Pattern ·····	69
11. Summarized Results from the Fermentation of 58.2 g/L Glucose with 20% Soy Oil ·····	70
12. Immobilized Culture Results for Fermentation of Glucose Media ·····	84

LIST OF FIGURES

1. Schematic of traditional steam stripping distillation of ABE fermentation products (from Mariano and Filho, 2012) ·····	2
2. Production targets according to the U.S. renewable fuel standard (from Wallner et al, 2012) 7	
3. Metabolic pathways in a fermentation of glucose by <i>Clostridium beijerinckii</i> ·····	14
4. Immobilized culture apparatus flowing with 3.5% glucose medium ·····	38
5. Airlock used to avoid back-contamination of media reservoir ·····	39
6. Immobilized cell column filled with ceramic Raschig rings ·····	39
7. Growth curves transfigured to the natural log of the absorbance at 660 nm as a function of temperature ·····	41
8. Doubling rate during logarithmic growth phase of <i>C. beijerinckii optonii</i> at different temperatures ·····	42
9. The pH during the fermentation of 31.1 g/L glucose with 1.0 mg/L FeSO ₄ ·7H ₂ O ·····	44
10. Totals of the glucose, total organic acids and total solvents during the fermentation of 31.1 g/L glucose with 1.0 mg/L FeSO ₄ ·7H ₂ O ·····	45
11. Formation of solvents during the fermentation of 31.1 g/L glucose with 1.0 mg/L FeSO ₄ ·7H ₂ O ·····	46
12. Microscopic images of <i>C. beijerinckii optonii</i> cultures grown in 31.1 g/L glucose medium with 1.0 mg/L FeSO ₄ ·7H ₂ O ·····	47
13. The pH of a fermentation of 28.3 g/L glucose with 1.5 mg/L FeSO ₄ ·7H ₂ O ·····	48
14. The total glucose, acids and solvents during a fermentation of 28.3 g/L glucose with 1.5 mg/L FeSO ₄ ·7H ₂ O ·····	49
15. Concentration of solvents generated during the fermentation of 28.3 g/L glucose with 1.5 mg/L FeSO ₄ ·7H ₂ O ·····	50
16. Microscopic images of <i>C. beijerinckii optonii</i> culture grown in 28.3 g/L glucose medium with 1.5 mg/L FeSO ₄ ·7H ₂ O ·····	51
17. The average pH and absorbance at 660 nm during two individual fermentations of glucose in the presence of 2.0 mg/L FeSO ₄ ·7H ₂ O ·····	52

18. The average total glucose, acids and solvents during two fermentations glucose with 2.0 mg/L FeSO ₄ ·7H ₂ O plus and minus the sample standard deviations	53
19. Concentration of solvents generated during two fermentations of glucose in the presence of 2.0 mg/L FeSO ₄ ·7H ₂ O	54
20. Microscopic images of <i>C. beijerinckii optonii</i> culture grown in P2 media containing 31.9 g/L glucose and 2.0 mg/L FeSO ₄ ·7H ₂ O	55
21. The pH during fermentation of 27.6 g/L glucose with 0.5 mg/L FeSO ₄ ·7H ₂ O	56
22. Totals of the glucose, organic acids and total solvents during the fermentation of 27.6 g/L glucose with 0.5 mg/L FeSO ₄ ·7H ₂ O	57
23. Formation of solvents during the fermentation of 27.6 g/L glucose with 0.5 mg/L FeSO ₄ ·7H ₂ O	58
24. Microscopic images of <i>C. beijerinckii optonii</i> cultures grown in 27.6 g/L glucose medium with 0.5 mg/L FeSO ₄ ·7H ₂ O	59
25. The pH and absorbance at 660nm during fermentation of 32.1 g/L glucose with 0.5 mg/L FeSO ₄ ·7H ₂ O with inhibitory pH compared to the pH and absorbance at 660nm in a fermentation of glucose with 0.5 mg/L FeSO ₄ ·7H ₂ O with normal pH pattern	60
26. The total glucose, acids and solvents during the fermentation of 32.1 g/L glucose with 0.5 mg/L FeSO ₄ ·7H ₂ O	61
27. Concentration of solvents generated during the fermentation of 32.1 g/L glucose with 0.5 mg/L FeSO ₄ ·7H ₂ O	62
28. Microscopic images of <i>C. beijerinckii optonii</i> culture grown in 32.1 g/L glucose with 0.5 mg/L FeSO ₄ ·7H ₂ O	63
29. The pH during fermentation of 30.1 g/L glucose with 2.0 mg/L FeSO ₄ ·7H ₂ O	64
30. The total glucose, acids and solvents during the fermentation of 30.1 g/L glucose with 2.0 mg/L FeSO ₄ ·7H ₂ O	65
31. Concentration of solvents generated during the fermentation of 30.1 g/L glucose with 2.0 mg/L FeSO ₄ ·7H ₂ O	66
32. Microscopic images of <i>C. beijerinckii optonii</i> culture grown in 30.1 g/L glucose with 2.0 mg/L FeSO ₄ ·7H ₂ O	67
33. The pH curves of each fermentation using glucose in P2 media	69

34. Total mass of glucose, butanol and total solvents during a fermentation of 58.2 g/L glucose with <i>C. beijerinckii optonii</i> with 20% oil added for coextraction ·····	71
35. pH curve during the fermentation of sugarcane juice medium containing 54.3 g/L total sugars by <i>C. beijerinckii optonii</i> ·····	72
36. Microscopic images of <i>C. beijerinckii optonii</i> cultures in sugarcane juice medium ·····	73
37. Concentrations of sugars during fermentation of sugarcane juice by <i>Clostridium beijerinckii optonii</i> ·····	74
38. Total sugars, acids and solvents during the fermentation of sugarcane juice medium ·····	75
39. Profile of solvents produced during fermentation of sugarcane juice medium by <i>C. beijerinckii optonii</i> ·····	76
40. The change in pH over 144 hours of fermentation of 38.2 g/L sugarcane molasses medium by <i>C. beijerinckii optonii</i> ·····	77
41. Individual sugars consumed by <i>C. beijerinckii optonii</i> in a fermentation of molasses medium containing 38.2 g/L fermentable sugar ·····	78
42. Total sugars, acids and solvents during the fermentation of 38.2 g/L fermentable sugar molasses medium using <i>C. beijerinckii optonii</i> ·····	79
43. Solvents produced during fermentation of 38.2 g/L fermentable sugar molasses medium using <i>C. beijerinckii optonii</i> ·····	80
44. Comparison of butanol and total solvents produced in fermentations of glucose and sugarcane products ·····	81
45. Productivity of fermentations using glucose and sugarcane products as substrates ·····	82
46. Yield of butanol produced per gram of sugar utilized in fermentations of glucose and sugarcane products ·····	83
47. Solvents produced by <i>C. beijerinckii optonii</i> in an immobilized continuous fermentation of 25 g/L glucose medium at various dilution rates ·····	85
48. Butanol productivity by <i>C. beijerinckii optonii</i> in an immobilized continuous fermentation of 25 g/L glucose medium at various dilution rates ·····	85
49. Average yields of butanol per gram of glucose by an immobilized culture of <i>C. beijerinckii optonii</i> at different dilution rates in a continuous fermentation of 25 g/L glucose medium ·	86

50. Microscopic images of samples from the continuous fermentation of 25 g/L glucose by <i>C. beijerinckii optonii</i>	87
51. Solvents produced by the fermentation of 30 g/L glucose in the immobilized culture of <i>C. beijerinckii optonii</i>	88
52. Butanol yield from glucose in fermentation of 30 g/L glucose medium using immobilized <i>C. beijerinckii optonii</i> culture	88
53. Productivity of butanol in the immobilized cell column using 30 g/L glucose medium at various dilution rates	89
54. Energy requirement for complete dehydration of butanol and the wastewater generated (from Mariano et al, 2011)	98

ABSTRACT

With an unpredictable market for gasoline and increased concerns with the pollution created by burning fossil fuels, there is a push for developing suitable replacements for gasoline. While corn-based ethanol production is the most common renewable biofuel produced in the United States, ethanol is not an ideal solution to gasoline replacement due to low energy density, hygroscopic and corrosive properties and inability to purify by distillation alone.

Higher alcohols such as butanol do not have the same problems with energy density, purification and hygroscopic and corrosive properties. The fermentation of butanol by using solventogenic *Clostridium* species, creating acetone, butanol and ethanol (known as ABE fermentation) is one of the world's oldest industrial fermentations. Since butanol is toxic to *Clostridium* species at a concentration of only 13 g/L, traditional batch fermentation of butanol with steam stripping distillation is currently not as economical as fermentation and distillation of ethanol.

Fermentation using glucose produced higher solvent outputs, rates of productivity and yields than fermentations using sugarcane products as substrates. Butanol and total solvent production using glucose as a substrate averaged 7.2 (+/- 0.7) g/L and 11.2 (+/- 0.9) g/L, respectively. Fermentation using sugarcane molasses and sugarcane juice as substrates produced 6.5 g/L butanol and 9.7 g/L total solvents and 3.1 g/L butanol and 4.0 g/L total solvents, respectively. Production of butanol was increased to 9.1 g/L in a fermentation of glucose when soy oil was used as a coextractant.

Fermentations in which the pH dropped below 4.80 showed decreased solvent production and the pH was unable to rise in the same manner as other fermentations. The acid crash was exhibited in several batch fermentations as well as continuous fermentation using an

immobilized culture of *C. beijerinckii optonii*. The acid crash resulted in lowered solvent production, low pH and physiological differences in the cells in the culture.

Fermentation using immobilized culture produced a maximum 5.4 g/L butanol and 6.8 g/L total solvents at a dilution rate of 0.18 hr^{-1} and 25 g/L initial glucose. Higher glucose levels and different dilution rates gave lower butanol and total solvent productions.

I. INTRODUCTION

Butanol, a saturated four-carbon aliphatic alcohol can be produced by fermentation by *Clostridium spp.* bacteria (Jones and Woods, 1986). It is used primarily in the chemical industry as an intermediate for the production of butyl acrylate, butyl methacrylate, butyl acetate and some glycol esters. It is also commonly used as an industrial solvent, in the production of plastic, hydraulic fluid, medical extractant and an ingredient in some detergents (EPA, 1998). The anaerobic fermentation known as the acetone-butanol-ethanol (ABE) fermentation is one of the oldest industrial fermentations, dating back to 1911, when there was a push to produce amyl alcohol, butanol and acetone as precursors to synthetic rubber (Durre, 2008). Further developments in the ABE process during World War I were driven by the need to produce acetone, a crucial solvent used in smokeless powder production. Until the 1920s, butanol was considered an unwanted by-product of the ABE fermentation process. This changed when butanol and butyl acetate were discovered to be great solvents for nitrocellulose lacquer, a commonly used finish in the automotive industry (Jones and Woods, 1986).

Separation of butanol from the ABE fermentation broth was by distillation through a series of five distillation columns (Mariano and Filho, 2012). The first column removed solids, acetic acid and butyric acids. The second column removed the acetone, the third column removed the ethanol and a portion of the water and the last two distillation columns were attached to a decanter which moves the upper layer containing 79.9% butanol to one distillation column and the lower layer containing 7.7% butanol was recycled to the other distillation column. The end product is 99.9% pure butanol. (Mariano and Filho, 2012). Figure 1 shows the schematic of traditional steam stripping distillation of butanol from ABE fermentation broth.

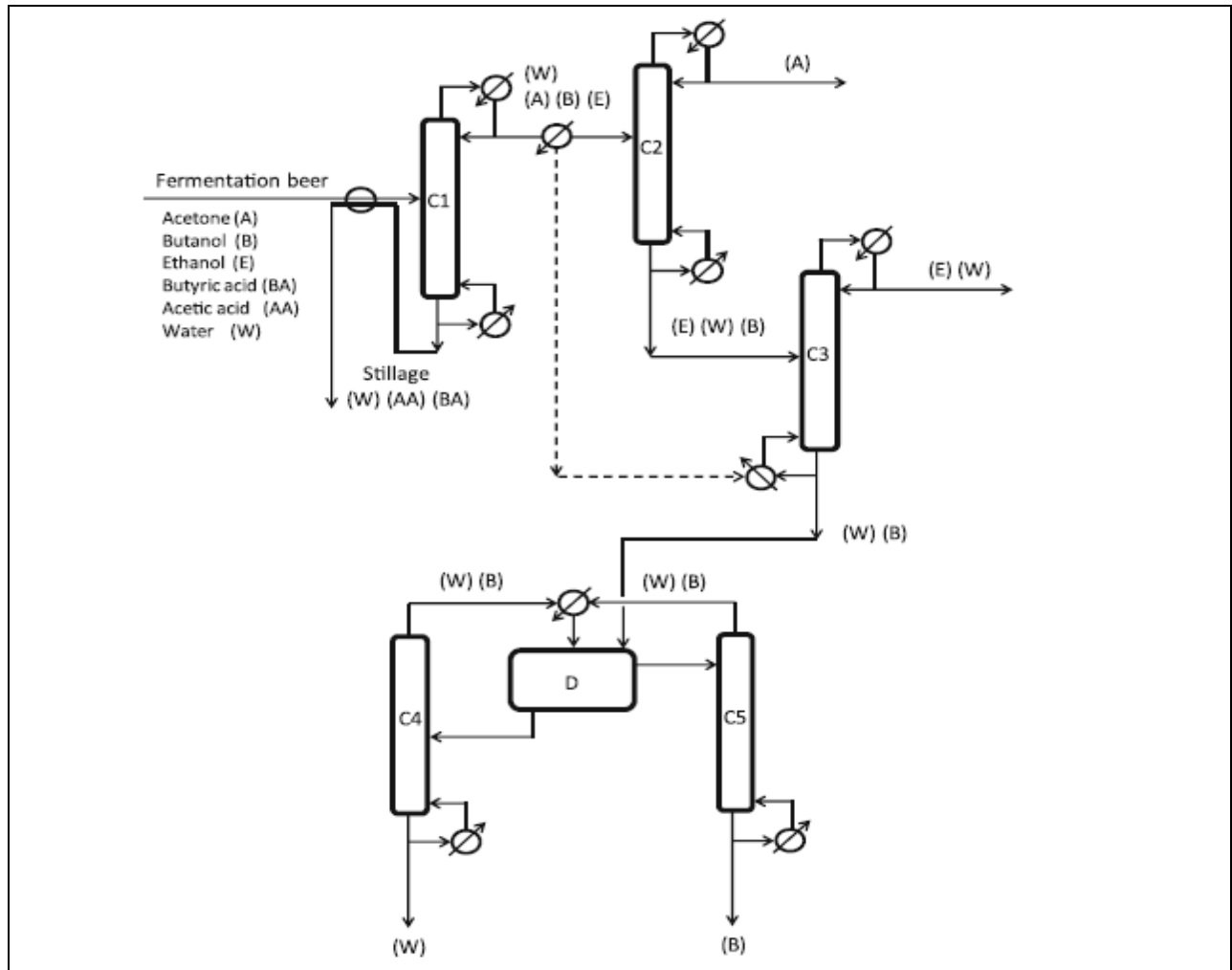

Figure 1 Schematic of traditional steam stripping distillation of ABE fermentation products (from Mariano and Filho, 2012)

During the first half of the twentieth century, the ABE fermentation was the most common industrial-scale fermentation process after ethanol. This production process was stopped in the 1950s because petroleum-based products were more economical to produce (Jones and Woods, 1986).

Butanol is superior to the lower alcohols in terms of its fuel-related properties. Table 1 shows that butanol has higher energy content and air:fuel ratio than ethanol or methanol, and each of those properties are closer to those of gasoline.

Table 1 Motor-Related Properties of Alcohols and Gasoline

	Methanol	Ethanol	Butanol	Regular Gasoline
Energy Content (BTU/gallon) _a	63,000	84,286	104,854	114,000
Motor Octane _b	N/A	88	84	87
Air:Fuel Ratio _a	6.6	9	11-12	12-15
Vapor Pressure (psi@100°F) _a	4.6	2	0.33	4.5

a –from Ramey, 2007

b – from Wallner et al, 2012

The drive to replace petroleum-based fuels has renewed the interest in the production of butanol via the ABE fermentation. The first objectives in this study are to determine the conditions a solventogenic strain, *Clostridium beijerinckii optonii*, can produce maximum amounts of butanol. Butanol production under a range of growth conditions and using various carbon sources were determined. To enhance butanol productivity, an immobilized cell system was developed, operated and scaled-up with goals of establishing a larger pilot system.

II. LITERATURE REVIEW

Alternatives to Fossil Fuels

Traditional fuel sources, primarily petroleum-based, are ultimately non-renewable. These fossil fuels are used to generate electricity, fuel transportation and provide heat. The United States consumed 18,835 thousand barrels of oil in 2011, 690.1 billion m³ of natural gas and 501.9 million tons of coal (BP Statistical Review, 2012). With an increasing world population, the demand for energy has been increasing at a staggering rate, such that traditional fossil fuel energy sources may potentially become limiting. The burning of any fuel may contribute to the increased greenhouse gases (Canacki et al., 2013). Canacki et al. (2013) showed that by replacing gasoline with ethanol or methanol, the amount of CO, CO₂, NO, NO₂ and hydrocarbon emissions are reduced. This reduction of emissions comes at the cost of reducing engine efficiency and gas mileage. The combustion of alcohols, like ethanol and methanol in the presence of oxygen theoretically yields CO₂ and water, so it can be assumed that total emissions can be reduced by the replacement of gasoline by mixtures of smaller alcohols.

The push for developing new and cheaper energy has skyrocketed in recent years due to increases in price of fossil fuels and government mandates for renewable sources. The USDA passed the Food, Conservation and Energy Act (Farm Bill) in 2008 to provide an incentive to farmers to provide various feedstocks and land to be used for energy production (USDA 2009). The USDA agreed to provide one billion dollars in funding to create green jobs and create renewable bioenergy to help strengthen the rural economy, as well as reduce greenhouse gas emissions and air pollution. Several “dedicated energy crops” are being cultivated for use in second and third generation biofuels. These include sweet sorghum, energy cane, perennial grasses, wood and oil crops as well as micro and macroalgae.

First generation biofuels are made from crops that could be used as food, such as from sugars and conversion of food grade oils to biodiesel. Second generation biofuels refers to conversion of lignocellulosic biomass to fuels. Land that could be used to produce food is used for growing lignocellulosic crops for second generation biofuels. Third generation biofuels are fuels produced in areas not available for growing food, such as high-lipid algae to biodiesel (USDA 2009).

The federal government has focused on replacing gasoline with algal biodiesel and/or fermentation of alcohols produced by yeast and bacteria. Biodiesel is made by removing the glycerol from the fatty acids in triglycerides to make long-chain alkyl esters. The alkyl esters are traditionally obtained by taking a fat or oil and transesterifying it with alkaline (prepared with NaOH) or acidic (prepared with H₂SO₄) sodium methoxide to separate the fatty acids from the glycerol, then reacting the free fatty acids with methanol to make methyl esters, which are the main component of biodiesel (Shu et al. 2009). Biodiesel can also be made by a rapid reaction of fatty acids with supercritical methanol (Marulanda 2012). Biodiesel production can be used to create fuel from oil crops and high-lipid producing algae and is a sustainable practice for disposal of used cooking oils and inedible oils.

Biodiesel offers environmental advantages over petroleum diesel fuel due to producing lower CO, fine particulate matter, volatile organic chemicals and SO_x emissions, though biodiesel NO_x emissions are slightly higher than those from petroleum diesel (Ali et al. 2009, Tomic et al. 2013, Pattanaik et al. 2013). Biodiesel has some mechanical advantages over diesel because it provides added lubrication to the engine and has a lower combustion temperature than petroleum diesel, decreasing friction and wear to the engine (Tomic et al. 2013).

There is conflicting information on the power generated in burning biodiesel as opposed to traditional petroleum diesel fuel (Tomic et al 2013, Ali et al. 2013, Pattanaik et al. 2013). Biodiesel has another disadvantage compared to petroleum diesel with higher viscosity that may cause a break in the flow. Also, the fatty acids from unsaturated fats are susceptible to oxidation and denaturation. If saturated fatty acids, such as those found in palm oil or animal fats are used, they are less susceptible to oxidation but they have a higher cloud point temperature than unsaturated fatty acids, meaning they will solidify more readily and cannot be used in cooler environments (Ali et al. 2009). Petroleum diesel fuel can be blended with biodiesel at any percentage or run with methane-rich biogas effectively reducing fossil fuel needs (Pattanaik, 2013).

Ethanol has been used as a replacement for gasoline in blends up to 15% ethanol in standard engines and 85% in engines specially designed to run on E85 gasoline (Szulczyk, 2010). Ethanol lowers the efficiency of a spark-ignition engine because the energy output and air:fuel ratio for ethanol is lower than that for pure gasoline. Much research has been done toward increasing the efficiency of the internal combustion engine through modification of the compression factor of the engine (Blumberg et al., 2008; Zhuang and Hong, 2013; Cohn et al., 2005). Engines running on higher levels of ethanol blends in gasoline must compensate for a higher compression factor in order to achieve efficient firing in the pistons. This may be achieved by using a direct injection engine, rather than a standard indirect injection engine (Cohn et al., 2005).

Fuels that contain lower energy are more susceptible to causing engine knock, or the undesired rapid energy release due to autoignition of the end gas, which can damage the engine (Cohn et al., 2005). While the energy output of ethanol is much less than gasoline, 84,000

BTU/gallon of ethanol, in comparison to about 114,000 BTU/gallon of regular gasoline (Ramey, 2007), the octane rating of pure ethanol is around 88, in comparison to an octane rating of 87 with regular gasoline. With a higher octane rating and a high latent heat of vaporization, injection of ethanol can act as a knock suppressant in a direct injection engine (Blumberg et al., 2008).

While most of the current research devoted to gasoline replacement has been focused on ethanol production, other alcohols can, and have been used for fuel, including methanol, propanol, butanol and higher alcohols (Wallner et al, 2012). The current U.S. Renewable Fuel Standard requires an increase in advanced biofuels, or alcohols with 3 to 8 carbon atoms, of about 36,000,000,000 U.S. gallons from 2012 to 2022, while the grants funding production of corn-based ethanol will be limited to 15,000,000,000 gallons (Wallner et al, 2012). Figure 2 shows the projected renewable fuels production for the years 2008 to 2022.

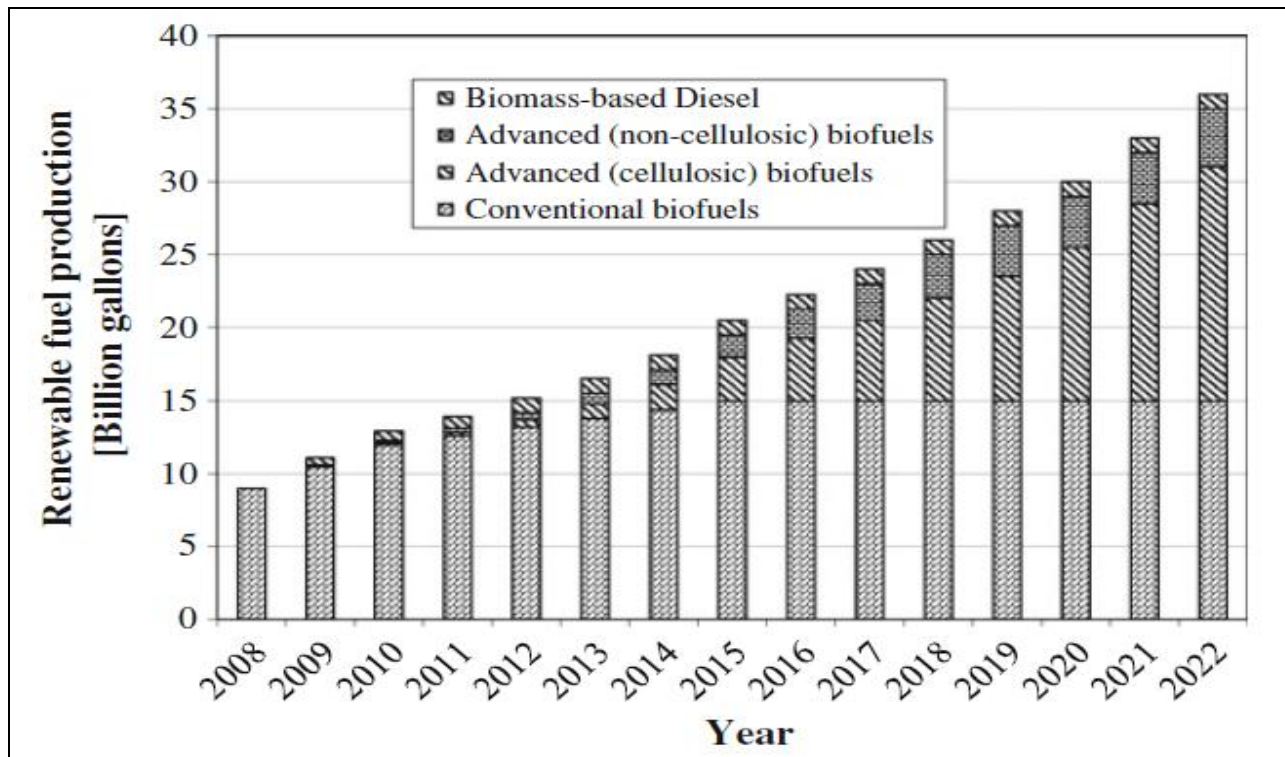

Figure 2 Production targets according to the U.S. renewable fuel standard (from Wallner et al, 2012)

Higher alcohols decrease engine knock, have higher air:fuel stoichiometric ratio and have lower latent heat of evaporation compared to ethanol. While all alcohols have a lower energy output compared to gasoline because of a higher oxygen content, this disadvantage is less pronounced in higher alcohols (Wallner et al, 2012). Also, the vapor pressure of the alcohol decreases as the number of carbon atoms in the alcohols increase, meaning higher alcohols will exhibit less loss due to vaporization compared to lower alcohols.

Fuel Properties of Butanol and Ethanol

The production of ethanol as a biofuel brings forth an issue with diverting potential resources that could be used for the production of food for the production of fuel. The hygroscopic characteristic and corrosiveness also make the transportation of ethanol in existing gasoline pipelines impossible. Because of these issues, the desirability of ethanol-based fuel are limited and butanol production is once again being considered (Wallner et al, 2012).

The energy output from the combustion of butanol is approximately 104,800 BTU/gallon, which is much closer to the value for gasoline than ethanol. Since the combustion energy is similar to gasoline, there would be less need to modify existing engines to run on butanol fuel. Butanol is non-corrosive and not hygroscopic, so it would be less damaging to engines and can use existing gasoline pipelines. As it does not readily absorb atmospheric moisture like ethanol, butanol can be used in marine fuels (Ramey, 2007, Zheng et al. 2009). Butanol is also less volatile than ethanol and gasoline so less would be lost to the atmosphere during transfer.

Butanol and ethanol are produced by fermentation of simple sugars and can be produced from similar feedstocks. The processes for fermentation are similar so minimal modifications would need to be made to current ethanol-producing plants for production of butanol. The production of butanol is impeded by a few drawbacks. Butanol is toxic to most solventogenic

Clostridium species at a concentration of 13 g/l, although some genetically modified strains can tolerate butanol concentrations up to 20 g/l (Zhu et al. 2011, Chen and Blaschek, 1999) whereas yeast has a tolerance of ethanol up to 200g/L. The stoichiometric conversion of butanol from glucose (Equation 1) shows a lower theoretical maximum yield compared to ethanol produced per unit glucose (Szulczyk 2010).

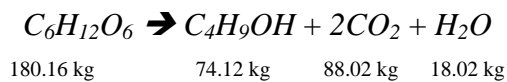
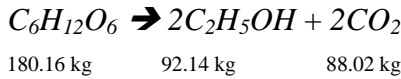

Equation 1 Stoichiometric conversion of glucose to ethanol and glucose to butanol

The fermentation of butanol by solventogenic strains of *Clostridium* species produces a mixture of solvents (ethanol, acetone and some strains produce 2-propanol) rather than pure n-butanol. Distillation of butanol is more costly than that of ethanol because the boiling point of butanol is higher than that of water. Also, the solventogenic *Clostridium* bacteria are often susceptible to infection by bacteriophages which may disrupt the RNA sequence and make the bacteria less able to produce butanol (Zheng et al. 2009).

***Clostridium* Genus**

The *Clostridium* genus of bacteria is a ubiquitous group of Gram positive bacilli, found in soil, sewage, vegetation, plant and animal products and the digestive tracts of many animals. Most are obligate anaerobes that grow best in a temperature between 30 °C and 37 °C and pH between 6.5 and 7.0. Most *Clostridia* produce non-vegetative spores that are able to withstand high temperatures, oxygen contamination, acidic or basic conditions (Sneath et al., 1986). The *Clostridium* genus is well known to the food industry, specifically the canning industry for there are pathogenic strains that cause food-borne illness. *C. perfringens*, *C. colinum* (Roussan et al.

2012), *C. botulinum*, *C. difficile* and *C. sordellii* (Sneath et al. 1986) are some of the known pathogenic strains of *Clostridium* bacteria.

There are five major species of *Clostridium* bacteria that produce butanol as a metabolite. Those solventogenic bacteria are *C. acetobutylicum*, *C. butyricum*, *C. saccharoperbutylacetonicum*, *C. beijerinckii*, *C. pasteurianum* is also known to produce butanol (Keis et al. 1995, Dhamole et al. 2012). *Clostridium beijerinckii*, one of the original solventogenic strains was originally classified as *Clostridium acetobutylicum*. Some of the strains of *Clostridium beijerinckii* were originally classified as *Clostridium acetobutylicum* and many of the strains from each species were later found to be *C. saccharoperbutylacetonicum* and *C. saccharobutylicum* (Shaheen et al. 2000). *Clostridium saccharoperbutylacetonicum* N1-4 and N1-504 were originally classified as *Clostridium acetobutylicum*. The use of these strains in an industrial setting dates back to 1938, but they were later reclassified as separate species (Johnson et al, 1997 and Keis et al, 2001).

In 1862, Louis Pasteur described the production of a C4 alcohol using a microbe he called “Vibron butyrique”, which was most likely a mixed culture containing a solventogenic *Clostridium* species (Durre, 2008). In the late 1870s, Albert Fitz was the first microbiologist to document an isolated species that could produce butanol, which he named *Bacillus butylicus*. In 1893, Martinus Beijerinck isolated and gave a detailed description of a similar strain of solventogenic bacterium which he called *Granulobacter saccharobutyricum*. In 1926, these solventogenic bacteria were classified as *Clostridium acetobutylicum* (Durre, 2008).

Many of the early strains of solventogenic *Clostridia*, which are still used in butanol fermentation research today, were isolated from river mud, sewage, soil, manure, roots, rotted wood and corn stalks (Beesch, 1952). By 1927, the practice of harvesting and isolating

solventogenic *Clostridium* species from these matrices was well established. The environmental matrices were placed in 4% corn mash, boiled for 2 minutes inside sealed test tubes and grown anaerobically for 48 to 72 hours. Test tubes that produced a foamy head and smelled of butyric acid and butanol were plated, isolated and dried on sterile sand for long-term storage. The isolated strains of solventogenic *Clostridium* bacteria were used in large-scale industrial fermentations, using fermenters with 60,000 to 500,000 gallon capacities.

Each species of solventogenic *Clostridium* bacteria produce acetone, butanol and ethanol in different and unique concentrations. Some strains have an additional enzyme, a secondary alcohol dehydrogenase, that converts acetone to isopropanol (Hanai et al., 2007). All four species of solventogenic *Clostridia* are known to ferment glucose, fructose, sucrose, arabinose, xylose, mannose, cellobiose, lactose, maltose, raffinose, salicin, amygdalin, starch and dextrin (Keis et al. 2001). Other carbon sources fermented by solventogenic *Clostridia* are shown in Table 2.

***Clostridium* Metabolism**

Clostridium species are able to ferment sugars and starches from a variety of real world sources, such as sugarcane products (Ni et al, 2012), maize (Parekh et al. 1998), lignocellulosic biomass (Ezeji et al. 2007), cheese-making bi-products (Napoli et al. 2010), cassava (Thang et al. 2010), fruit and vegetable waste (Survase et al, 2013) and other glucose containing carbon sources. The carbon sources used for fermentation are initially converted to pyruvate prior to the generation of the solvent end products. The ABE fermentation happens in two phases: the acidogenesis phase and the solventogenesis phase. The carbon sources used are converted to acetic acid and butyric acid during the acidogenesis phase of fermentation. The pH of the media typically drops from about pH 6.1 to about pH 4.7 as organic acids are produced. The starting

and ending pH can vary widely, as well as the time it takes for the pH to drop. The organic acids are converted to acetone, butanol and ethanol during the solventogenesis phase of fermentation. Some organisms contain a secondary alcohol dehydrogenase capable of converting acetone to 2-propanol (Dai et al. 2012).

Table 2 Carbon Sources Fermented by Four Major Solventogenic *Clostridium* Species (from Keis et al, 2011)

Species	<i>C. acetobutylicum</i>	<i>C. beijerinckii</i>	<i>C. saccharoperbutylacetonicum</i>	<i>C. saccharobutylicum</i>
Strains	7	16	2	4
Rifampicin resistance	Not resistant	Some strains resistant	Resistant	Not resistant
Riboflavin produced*	Yes	No	No	No
Gelatin liquefaction	Yes	No	Yes	Yes
Ferments:				
Ribose	No	Some strains yes	No	Weak
Glycerol	Weak	Weak	No	No
Arabitol	No	Most strains yes	Yes	Most strains yes
Dulcitol	No	Most strains yes	Some strains yes	No
Inositol	No	Yes	Some strains yes	Yes
Mannitol	Yes	Yes	Yes	Most strains yes
Sorbitol	Some strains yes	Yes	Some strains yes	No
Melezitose	Most strains no	Yes	Yes	No
Melibiose	Most strains no	Most strains yes	Yes	Yes
Rhamnose	No	Most strains weak	Weak	No
Trehalose	Most strains no	Yes	Yes	Yes
Turanose	Most strains weak	Yes	Yes	Yes
Glycogen	Yes	Most strains yes	Yes	Yes
Inulin	Some strains yes	Yes	Yes	Most strains yes
Pectin	Yes	Yes	Yes	No

*from Johnson et al, 1997

Once the acids begin to convert to solvents, the pH of the media rises to about pH 5.4. As with the acidogenesis phase, the end pH and time to reach the end pH can vary widely depending on the carbon source fermented. The pH typically rises and falls slightly towards the end of the fermentation as the microorganism attempts to establish equilibrium between acidogenesis and solventogenesis. Figure 3 (modified from Gheshlaghi et al, 2009) maps the common metabolic pathways in a fermentation using *Clostridium beijerinckii*.

The goal of the bacteria during fermentation is to create the most ATP possible without poisoning themselves with toxic levels of their metabolites. Aerobic organisms are able to utilize NADH to generate ATP via an electron transport system with oxygen as a terminal electron acceptor (Black, 2004). Anaerobic microorganisms like *Clostridium beijerinckii* do not have the ability to utilize the electron transport system to generate ATP and therefore must maintain a balance of NADH and NAD⁺. Table 3 shows the net gains of ATP and NADH or NAD⁺ from the conversion of glucose to ethanol, acetate, acetone, 2-propanol, butyrate or butanol.

The conversion of glucose to acetate, acetone or 2-propanol all yield net gains of NADH whereas conversion to butanol is a way for *Clostridium* species to regenerate NAD⁺ in this fermentation. The acetate and butyrate that are reduced during the solventogenesis phase of fermentation results in the conversion of acetoacetyl CoA to acetoacetate, and later acetone and then 2-propanol. The conversion of one molecule of acetate to ethanol yields a net gain of 2 NAD⁺ and the conversion of acetate to butanol yields 4 NAD⁺. The conversion of butyrate to butanol yields 2 NAD⁺.

The majority of the ATP is generated during the glycolysis phase of fermentation. Some of the acetyl CoA generated is used for lipid synthesis and growth but the majority of the acetyl

CoA is converted to acids and solvents. All solventogenic species of *Clostridia* produce different ratios of the acids and solvents produced.

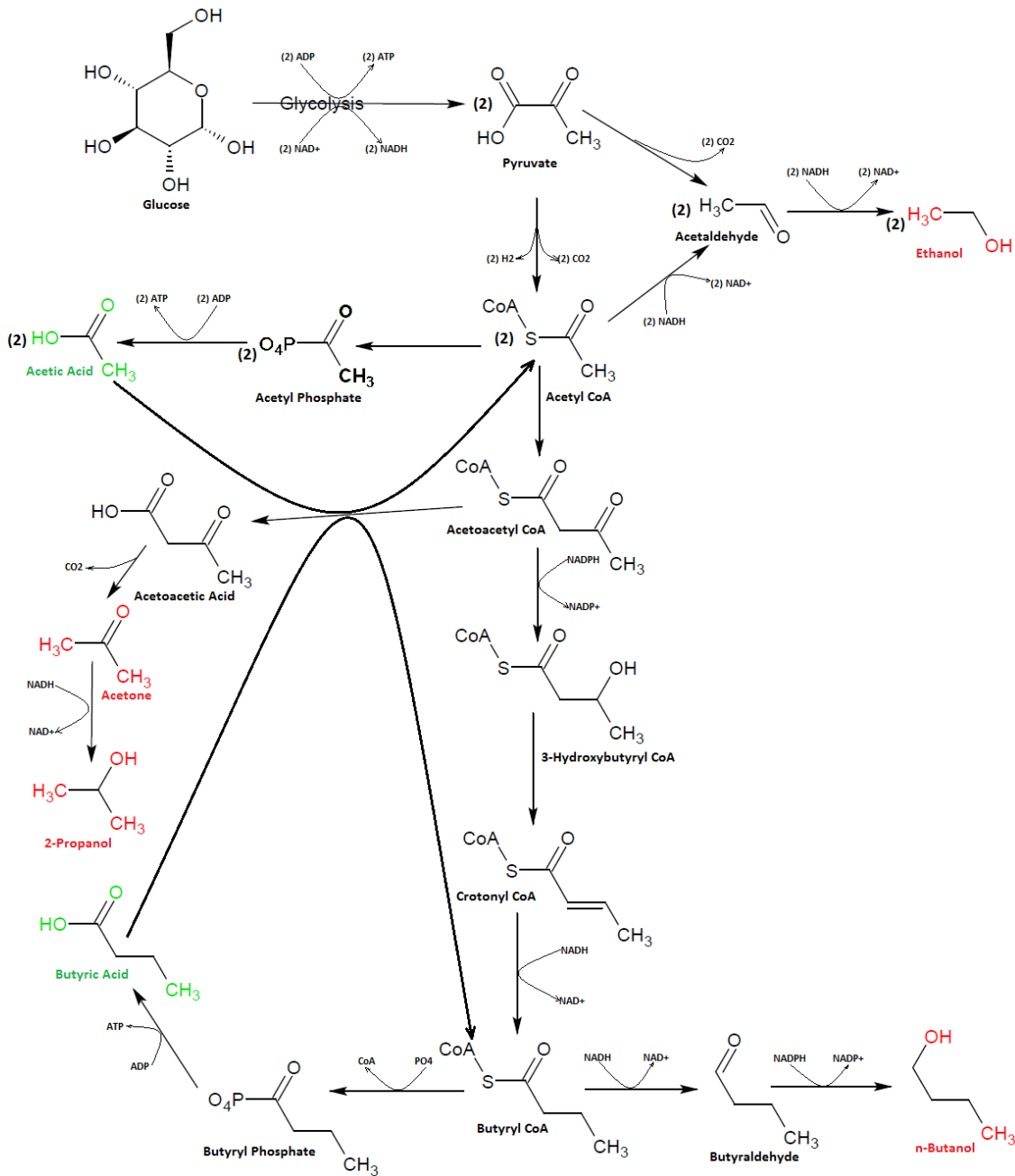

Figure 3 Metabolic pathways in a fermentation of glucose by *Clostridium beijerinckii*. Molecules highlighted in green are the organic acids produced and molecules highlighted in red are the solvents produced in the fermentation

The requirement of iron in all *Clostridium* species is due to the presence of the metalloenzymes, hydrogenase and three separate NADH-ferredoxin reductase enzymes

(Alshiyab et al, 2008, Guerrini et al, 2008). *C. acetobutylicum* has one [NiFe]-hydrogenase and two [FeFe]-hydrogenases, designated HydA1 and HydA2. Reduced ferredoxin is used in *Clostridium* metabolism as the electron donor to hydrogenase enzymes, which are in turn used to produce hydrogen, as butanol, ethanol and 2-propanol are produced during fermentation. It has been reported that the addition of divalent iron ions can help increase the speed of reactions involving the terminal acceptance of electrons since the early 1950s. Other divalent metal ions were tested and only divalent cobalt provided any activity in these enzymatic reactions (Wolfe and O’Kane, 1953).

Table 3 Possible Outcomes of Direct Fermentation of Glucose and the Yields of ATP and Balance of NADH/NAD⁺

Product of converting one glucose molecule (Number of molecules produced)	Net gain of ATP	Net gain of NADH or NAD⁺
(2) Ethanol	+2 ATP	0 (or +2 NAD ⁺)
(2) Acetate	+4 ATP	+2 NADH
(1) Acetone	+2 ATP	+2 NADH
(1) 2-propanol	+2 ATP	+1 NADH
(1) Butyrate	+3 ATP	0
(1) Butanol	+2 ATP	+2 NAD ⁺

The Ferric Uptake Regulator (*fur*) protein mainly used for maintaining iron homeostasis is regulated by the concentration of iron in the fermentation matrix. The *fur* protein is also used for flagellar movement, energy metabolism and oxidation-reduction stress resistance (Vasileva et al, 2012). As an obligatory anaerobic organism, *C. beijerinckii optonii* has the need for maintaining an oxygen-free cell. The concentration of iron is therefore indirectly involved in maintaining its oxygen-free intracellular matrix via the *fur* protein.

Clostridium bacteria have requirements for magnesium, a major component of the ribosomes within the cell and an enzyme cofactor in the cell walls and cell membranes (Alshiyab et al, 2008). The enzymes in which magnesium is involved are primarily kinases and

phosphatases. As magnesium is found to be the most prevalent metal within the bacterial cells, supplementation of magnesium is 20-fold higher than that of iron, manganese or sodium in the commonly P2 mineral solution (Qureshi and Blaschek, 1999).

Manganese is also provided in P2 supplementary mineral solution, as it is used in some enzymatic reactions requiring divalent metal ions as cofactors. The enzymatic activities of phospho- α -glucosidases and maltose-6'-phosphate hydrolases have requirements for Mn^{2+} and NAD^+ cofactors (Thompson et al, 2003). Other divalent metals including Fe^{2+} , Mg^{2+} , Co^{2+} or Ni^{2+} have very little effect on the activity of phospho- α -glucosidase or maltose-6'-phosphate hydrolase activities.

Calcium, which is not provided in supplementary P2 mineral solution, is known to be used in the formation of biofilms as it is used for adsorption and adhesion (Alshiyab et al, 2008). It is also used as a cofactor for alpha-amylase and some proteases. It is found, however, to adversely affect production of hydrogen during fermentation by *C. acetobutylicum*.

The P2 medium contains para-aminobenzoic acid (PABA) which is used as a growth factor by *Clostridium* species. As *Clostridium* species do not have PABA synthase, PABA must be supplied. Structurally similar compounds to PABA have been tested as to whether or not they could be utilized by *Clostridium acetobutylicum* for growth but those compounds had little to no activity compared to PABA (Housewright and Koser, 1944).

Thiamine is another vitamin essential for growth of *Clostridium* species. Along with iron, thiamine pyrophosphate is a cofactor in the ferredoxin oxidoreductase enzyme used to convert pyruvate to acetyl-CoA (Kletzin and Adams, 1996). It would be impossible for acidogenesis and solventogenesis to occur without the presence of thiamine.

Biotin is an essential cofactor for decarboxylase enzymes (Kress et al, 2009). As fermentative organisms, the lack of electron transport to create energy causes a need to conserve as much energy as possible. Biotin-dependent decarboxylase enzymes rest within the cell membrane and use the transport of sodium ions out of the cell's cytoplasm to catalyse the decarboxylation reactions (Kress et al, 2009). As shown in figure 3, decarboxylation reactions are used for the catalysis of acetone from acetoacetate and ethanol from pyruvate and are therefore necessary for the creation of solvents in order to reduce the pH of the fermentation medium.

Many different types of supplemental growth medium have been tested in order to achieve maximal solvent output by *Clostridia* species. The P2 medium used in all experiments performed in this document is one of the most common. Other supplementary growth media include RCM medium (reinforced clostridial media), containing 30 g/L glucose, 10 g/L peptone, 10 g/L beef extract, 3 g/L yeast extract, 5 g/L sodium chloride, 0.5 g/L cysteine HCl, 3 g/L sodium acetate, and 0.5 g/L agar, TYA (Tryptone, yeast extract acetate) medium, containing 30 g/L glucose, 0.5 g/L KH₂PO₄, 0.5 g/L K₂HPO₄, 0.4 g/L MgSO₄·7H₂O, 0.01 g/L MnSO₄·4H₂O, 0.01 g/L FeSO₄·5H₂O, 1.0 g/L yeast extract, and 0.5 g/L cysteine and AnS (anaerobic sugar) medium, consisting of 30 g/L glucose, 10 g/L peptone, 5 g/L yeast extract, 3 g/L K₂HPO₄, 1 g/L NaCl, 1 g/L (NH₄)₂SO₄, 0.2 g/L MgCl₂·6H₂O, 0.2 g/L CaCl₂·2H₂O, and 1 g/L Na₂CO₃. (Al-Shorgani et al, 2013). A study comparing P2, AnS, TYA and RCM media showed that RCM and AnS media produced less butanol and total ABE than P2 and TYA media in fermentations using a previously undescribed *Clostridium* bacteria, shown in Table 4. These results helped determine which levels of supplementary minerals provide the maximal solventogenic output.

Table 4 Comparison Between RCM, TYA, AnS and P2 Media Containing 30 g/L Glucose and the ABE Fermentation Results Using a Newly Discovered *Clostridium* Bacteria (from Al-Shorgani et al, 2013)

Medium	Glucose (g/L)		Solvent Production (g/L)				Acids Production (g/L)		ABE Yield (g/g)
	Initial	Residual	Acetone	Butanol	Ethanol	ABE	Butyric	Acetic	
RCM	30	7.67	0.93	1.60	0.02	2.54	0.99	0.05	0.10
TYA	30	0.64	2.66	6.20	0.07	8.93	0.35	0.04	0.24
AnS	30	18.03	0.95	3.24	0.02	4.22	0.65	0.04	0.29
P2	30	0.94	1.56	5.69	0.06	7.31	0.65	0.05	0.25

Batch Culture

Most fermentations are typically batch. Microbial growth in batch fermentation follows a progression of four phases: lag phase, growth (or log) phase, stationary phase and death phase (Black, 2004). The lag phase is defined by the active metabolism of the organisms without significant multiplication. The lag phase may last as short as a few hours or as long as a few days. The growth phase is the phase in which the numbers of the bacteria increase logarithmically. As long as nutrients are plentiful and conditions remain favorable for growth, the culture will remain in the logarithmic growth phase. The stationary phase of the batch culture occurs when the rate of cell division is approximately equal to the rate of cell death. The stationary phase begins once the nutrients become scarce or the metabolites reach a toxic level. The bacteria typically expel less energy and resources on reproduction in order to spend more energy towards their own survival. The death phase occurs once the levels of metabolites reach a toxic level and the competition between organisms for nutrients becomes too great and the organisms begin to die faster than the organisms multiply. The number of live organisms declines at a logarithmic rate during the death phase.

Different additives to the media for batch cultures using *Clostridium* species have been studied extensively. These bacteria have requirements for a carbon-based substrate, protein, 4-aminobenzoic acid, thiamin, biotin, iron (Gheshlaghi et al. 2009) and magnesium. Media

containing complex vegetable matter generally provide the vitamins and minerals required by the *Clostridia* organisms for fermentation. Fruits and vegetables can provide gratuitous amounts of vitamins, minerals, amino acids and other growth factors that can help promote increased solvent production from fermentation using *C. acetobutylicum*. Survase et al (2013) used 5% (w/v) carrot, cabbage and tomato waste supplement growth using glucose as the primary fermentation substrate and found that total solvent production was doubled in a 96 hour fermentation time.

Parekh et al. (1998) has showed that 60 g/L glucose medium containing corn-steep water has the amino acids, nitrogen, vitamins and minerals needed by *Clostridium beijerinckii* BA101 for growth and solvent production. Addition of autoclaved corn-steep water did not aid in fermentation, whereas filter-sterilized corn-steep water to glucose medium gave similar results to addition of filter-sterilized 4-aminobenzoic acid, thiamine and biotin. The addition of vitamins, proteins, buffers, sodium, manganese or magnesium to media containing corn-steep water had little effect on the butanol production but addition of $\text{FeSO}_4 \cdot 7\text{H}_2\text{O}$ further increased butanol production by 26% and doubled the butanol/acetone ratio.

An initial addition of acetate has been found to boost sugar consumption and butanol production and protect the bacteria from denaturing by the solvents produced. The highest recorded concentration of butanol in a batch fermentation using solventogenic *Clostridium* bacteria was 20.9 g/L, found by using 8% glucose and 60 mM sodium acetate as the fermentation substrates for *Clostridium beijerinckii* BA101 (Chen and Blaschek, 1999).

Studies show that the effects of additional acetate to fermentation media on the production of butanol are greater with addition of butyrate, even at lower concentrations of additional acids. Addition of 36mM acetate to fermentation media increases the production from a negligible amount of butanol in the control to 9.4 g/L whereas the addition of 9mM of butyrate

can boost butanol production to 10.6 g/L and addition of 36 mM butyrate can boost butanol production to 11.2 g/L (Lee et al, 2008). Table 5 shows various results of ABE production using batch cultures.

Table 5 Various ABE Batch Fermentation Results

Species	Carbon Source	Conditions	Yields (g/L)	Source
<i>C. saccharoperbutylacetonicum</i> N1-4	Cassava starch (66g/L)	Batch fermentation with N ₂ sparge prior to inoculation. 30°C.	Acetone – 3.6 Butanol – 16.9 Ethanol – 0.5	Thang et al. 2010
<i>C. saccharoperbutylacetonicum</i> N1-4	Hydrolyzed cassava chips (66g/L)	Batch fermentation with N ₂ sparge prior to inoculation. 30°C.	Acetone – 5.8 Butanol – 16.2 Ethanol – 1.0	Thang et al. 2010
<i>C. saccharoperbutylacetonicum</i> N1-4	Glucose (66g/L)	Batch fermentation with N ₂ sparge prior to inoculation. 30°C.	Acetone – 7.0 Butanol – 16.2 Ethanol – 1.0	Thang et al. 2010
<i>C. acetobutylicum</i> ATCC 824	Glucose (80g/L)	72 hour batch fermentation at 37°C	Acetone – 4.09 Butanol – 10.1 Ethanol – 1.17	Ventura et al. 2013
<i>C. acetobutylicum</i> ATCC 824 with overexpressed <i>pfka</i>	Glucose (80g/L)	72 hour batch fermentation at 37°C	Acetone – 4.06 Butanol – 10.6 Ethanol – 1.30	Ventura et al. 2013
<i>C. acetobutylicum</i> ATCC 824 with overexpressed <i>pyka</i>	Glucose (80g/L)	72 hour batch fermentation at 37°C	Acetone – 3.85 Butanol – 11.9 Ethanol – 1.96	Ventura et al. 2013
<i>C. acetobutylicum</i> ATCC 824 with overexpressed <i>pfka</i> and <i>pyka</i>	Glucose (80g/L)	72 hour batch fermentation at 37°C	Acetone – 3.61 Butanol – 13.07 Ethanol – 2.17	Ventura et al. 2013
<i>C. acetobutylicum</i> ATCC 824	Extruded Corn Broth Medium (14%)	96 hour batch fermentation at 37°C	Butanol – 12.6 Total ABE – 21.35	Lin and Blaschek 1983
<i>C. acetobutylicum</i> ATCC 824 mutant strain SA1 (serial addition)	Extruded Corn Broth Medium (14%)	96 hour batch fermentation at 37°C	Butanol – 13.9 Total ABE – 21.72	Lin and Blaschek 1983
<i>C. acetobutylicum</i> ACTT 824	Glucose (60 g/L)	Batch fermentation at 37°C	Acetone – 3.1 Butanol – 12.9 Ethanol – 1.3	Lehmann et al, 2012

Table 5 (Continued)

Species	Carbon Source	Conditions	Yields (g/L)	Source
<i>C. acetobutylicum</i> ACTT 824 butyrate knockout mutant	Glucose (60 g/L)	Batch fermentation at 37°C	Acetone – 0.1 Butanol – 3.4 Ethanol – 0.3	Lehmann et al, 2012
<i>C. acetobutylicum</i> ACTT 824	Glucose (60 g/L)	Batch fermentation at 37°C with pH control ≥ 5.0 , fed batch	Acetone – 6.3 Butanol – 12.4 Ethanol – 1.9	Lehmann et al, 2012
<i>C. acetobutylicum</i> ACTT 824 butyrate knockout mutant	Glucose (60 g/L)	Batch fermentation at 37°C with pH control ≥ 5.0 , fed batch	Acetone – 4.2 Butanol – 7.8 Ethanol – 32.4	Lehmann et al, 2012
<i>C. acetobutylicum</i> DSM 792	Glucose (50g/L)	96 hour batch fermentation 37°C	Total ABE – 8.18	Survase et al, 2013
<i>C. acetobutylicum</i> DSM 792	Glucose (50g/L) with 5% cabbage supplement	96 hour batch fermentation 37°C	Total ABE – 17.94	Survase et al, 2013
<i>C. acetobutylicum</i> DSM 792	Glucose (50g/L) with 5% carrot supplement	96 hour batch fermentation 37°C	Total ABE – 17.70	Survase et al, 2013
<i>C. acetobutylicum</i> DSM 792	Glucose (50g/L) with 5% tomato supplement	96 hour batch fermentation 37°C	Total ABE – 16.27	Survase et al, 2013
<i>C. acetobutylicum</i> M5 mutant	Glucose (80 g/L)	40 hour batch fermentation at 37°C	Butanol – 11.1 Ethanol – 2.0	Sillers et al, 2008
<i>C. beijerinckii</i> BA101	Glucose (55g/L)	Batch fermentation at 35°C in 175 ml screwcap bottle	Acetone – 4.2 Butanol – 13.1 Ethanol – 0.5	Eziji et al. 2007
<i>C. beijerinckii</i> BA101	Xylose (55g/L)	Batch fermentation at 35°C in 175 ml screwcap bottle	Acetone – 4.2 Butanol – 12.7 Ethanol – 0.6	Eziji et al. 2007
<i>C. beijerinckii</i> BA101	Cellobiose (55g/L)	Batch fermentation at 35°C in 175 ml screwcap bottle	Acetone – 4.3 Butanol – 13.9 Ethanol – 0.9	Eziji et al. 2007
<i>C. beijerinckii</i> BA101	Mannose (55g/L)	Batch fermentation at 35°C in 175 ml screwcap bottle	Acetone – 2.2 Butanol – 1.9 Ethanol – 0.6	Eziji et al. 2007
<i>C. beijerinckii</i> BA101	Arabinose (55g/L)	Batch fermentation at 35°C in 175 ml screwcap bottle	Acetone – 3.1 Butanol – 13.3 Ethanol – 0.7	Eziji et al. 2007

Table 5 (Continued)

Species	Carbon Source	Conditions	Yields (g/L)	Source
<i>C. beijerinckii</i> BA101	Galactose (55g/L)	Batch fermentation at 35°C in 175 ml screwcap bottle	Acetone – 2.1 Butanol – 7.8 Ethanol – 0.4	Eziji et al. 2007
<i>C. beijerinckii</i> BA101	Glucose (60g/L)	Batch fermentation at 36°C in 175 ml screwcap bottle	Acetone – 4.8 Butanol – 19.7 Ethanol – 0.8	Qureshi and Blaschek 2000
<i>C. beijerinckii</i> NCIMB 8052	Glucose (30 g/L)	Batch at 37°C with 18mM added butyrate	Acetone – 4.2 Butanol – 10.2 Ethanol – 0.3	Lee et al. 2008
<i>C. beijerinckii</i> NCIMB 8052	Glucose (30 g/L)	Batch at 37°C with 36 mM added acetate	Acetone – 6.8 Butanol – 9.8 Ethanol – 0.3	Lee et al. 2008
<i>C. beijerinckii</i> BA101	Glucose (60 g/L)	Batch culture at 35°C with no added acetate	Total ABE – 6.1	Chen and Blascheck 1999
<i>C. beijerinckii</i> BA101	Glucose (60 g/L)	Batch culture at 35°C with 60mM added acetate	Butanol – 18.6 Total ABE – 26.1	Chen and Blascheck 1999
<i>C. beijerinckii</i> BA101	Glucose (80 g/L)	Batch culture at 35°C with 60mM added acetate	Butanol – 20.9 Total ABE – 32.6	Chen and Blascheck 1999
<i>C. beijerinckii</i> BA101	Glucose (60 g/L)	Batch culture at 30°C with 1.6% corn-steep water	Butanol – 14.5 Total ABE – 20	Parekh et al. 1998
<i>C. beijerinckii</i> NCIMB 8052	Glucose (60 g/L)	Batch culture at 30°C with 1.6% corn-steep water	Butanol – 10.7 Total ABE – 14	Parekh et al. 1998
<i>C. saccharobutylicum</i>	Molasses (60 g/L total sugar)	Batch fermentation at 35°C	Butanol – 11.86 Total ABE – 11.78	Ni et al, 2012

Mutagenic Research to Increase Solvent Production

While it is implied that the *Clostridium* bacteria must first generate acetic acid and butyric acid prior to the production of butanol, the generation of butyric acid is not necessary for the production of butanol. Knock-out mutants that are unable to generate butyrate produce far less butanol, acetone or ethanol, while generating higher amounts of lactic acid and acetic acid in comparison to the control. However, under fed-batch conditions where the pH is controlled to

stay above 5.0, the knock-out mutants can generate a 16-fold higher amount of ethanol. The knock-out mutants produce slightly lower butanol (7.8 g/L compared to 12.4 g/L) and acetone (4.2 g/L compared to 6.3 g/L) than the control, but with the increased ethanol production (32.4 g/L compared to 1.9 g/L), the total solvents produced increased substantially (44.4 g/L compared to 20.5 g/L) (Lehmann et al (B), 2012). The reason for the increase in ethanol production in the knock-out mutant is that the oxidation-reduction balance within the cell must be compensated as the downstream production of butyrate and butanol regenerates a high amount of NAD^+ (Lehmann and Lutke-Eversloh, 2011). The generation of ethanol can replace NAD^+ as shown in Table 3 and Figure 3. By knocking out the genes responsible for generation of acetone or acetate, lower amounts of solvents are produced by *Clostridium acetobutylicum* (Lehmann et al (B) 2012). While it could be assumed that lower amounts of acetate would generate higher amounts of butyrate and butanol, the concentration of butanol produced by knock-out mutants unable to produce acetate is decreased by nearly 70% compared to the control. The concentration of butyrate in the acetate-negative mutants increased by over 300% compared to the control. This caused an “acid crash”, stopping production of butanol. Knock-out mutants unable to produce acetone did not experience “acid crash” but butanol concentration was decreased by 30%.

In fermentations using acetate kinase knock-out mutants with the pH set at 5.0, however, production of butanol was increased when compared to a control batch (Kuit et al, 2012). Acetate kinase knock-outs did not completely eliminate the production of acetate, but rather slowed its formation. The delay in acetic acid formation increased the concentration of butyrate in the first 10 hours and increased the final butanol concentration by 16% while having little effect on the production of acetone or ethanol.

The *Clostridium* species are known to form non-vegetative spores at the beginning of the solventogenic stage of batch fermentation (Zheng et al, 2009). While these spores are made to protect the bacteria from hazardous growth conditions in order to survive until conditions become right for growth, the formation of spores requires large amounts of energy. It is theorized that butanol production may be enhanced by delaying or eliminating sporulation.

Mutations to *Clostridia* are not specifically limited to knock-out mutants. Mutations can be achieved by the introduction of plasmids to over-express genes for production of solvents. By adding a plasmid containing the alcohol/aldehyde dehydrogenase-producing gene (*aad*) to a non-solventogenic, non-sporulating strain of *Clostridium acetobutylicum*, the strain can regain its ability to produce solvents (Sillers et al, 2008). The addition of the *aad* gene to the M5 *C. acetobutylicum* strain gives the ability for this bacterium to produce butanol without producing acetone. The highest producing mutant strain was able to produce 11.1 g/L butanol and 2.0 g/L ethanol without acetone.

Solventogenic genes can be added to *E. coli* to create more robust bacteria capable of performing ABE fermentations (Mariano and Filho, 2012, Shen et al, 2011). Early developments in transgenic modifications to *E. coli* showed extremely low butanol productivity but the works of Shen et al (2011) provided *E. coli* the ability to produce 15 g/L butanol in batch fermentation as opposed to the typical production of less than 1 g/L performed by previous researchers.

The process of serial enrichment can help guide evolution to selectively improve certain traits, such as improving tolerance for butanol. Lin and Blaschek (1983) improved the butanol tolerance of *C. acetobutylicum* by introducing g/L butanol to a culture 30 minutes after inoculation. The process was repeated using the cultures that exhibited the greatest growth. The

serially enriched mutants (SA-1) were able to produce 13.9 g/L butanol during a fermentation of 14% sugar extruded corn broth medium, which was 10.3% more butanol than the original strain which produced 12.6 g/L butanol. The SA-1 mutants not only produced higher amounts of butanol, but it also produced a higher percentage of butanol in the total solvents. The SA-1 mutants also had a growth rate that was nearly twice as fast as the original strain. The use of serial enrichment can help improve many of the fermentation traits when using *Clostridium* species.

Atmospheric pressure glow discharge is another method for mutating bacteria. Similar to chemical, heat or UV treatment, glow discharge can be used to mutate bacteria and selectively eliminate bacteria that cannot survive short duration of treatment (Guo et al, 2011). By using plasma glow discharge treatment, the more robust bacteria survive while the weaker bacteria are eliminated. Guo et al (2011) used plasma glow discharge treatment to improve the robustness of *C. beijerinckii* NCIMB 8052 and improve the production of butanol and total ABE from fermentation of 30 g/L glucose. The treated strains were able to produce 10.3 g/L butanol and 13.7 g/L total solvents whereas the wild-type bacteria produced 7.8 g/L butanol and 11.2 g/L total solvents.

Immobilized Culture

Microbial cultures may be used in immobilized. An immobilized culture is made by immobilizing cells to a surface and flowing media past the immobilized cells. The culture may be kept in a continuous state of growth and/or production in an immobilized culture and therefore eliminates the lag phase as the bacteria are continuously growing and reproducing (Hoskisson and Hobbs, 2005). The death phase is also downplayed because the dead bacteria and waste products are expelled before the waste buildup becomes toxic. The bacteria in a liquid

batch solution constantly use energy for movement to find food and evenly distribute in the media to prevent overcrowding but the bacteria in an immobilized culture adhere to surfaces and create biofilms that allow the bacteria to grow a colony where the food source passes, thus decreasing the need for motility.

Porous material allows high surface area for biofilms to form within the material. Survase et al. (2013) experimented with different types of porous material as immobilization matrices, including coconut fiber, wood pulp, wood chips, sugarcane bagasse and loofa sponge for a continuous fermentation of butanol and 2-propanol using *Clostridium beijerinckii* DSM 6423.

Immobilized cell production of ethanol studies showed improvements over suspended cell batch fermentations in a study using silk cocoons as an immobilization matrix for yeast cells (Rattanapan et al., 2011). The production of ethanol was increased by 11.5% in 72 hours of continuous fermentation over batch fermentation and utilization of sugar to ethanol on a gram-per-gram basis was increased by 9.3%, thus showing that immobilized fermentation can improve yield while decreasing the amount of sugar needed for fermentation. The greatest advantage with an immobilized fermentation over batch fermentation in this study was the 12.6-fold increase productivity in terms of g/(L x h) with the continuous flow of feedstock to the immobilized cells.

Research on the use of immobilized cultures for butanol production has been studied with several different types of *Clostridia* and show promising results. Lee et al. (2008) found that a continuous fermentation of 30 g/L glucose with an additional 18mM of sodium butyrate using suspended *Clostridium beijerinckii* cells could continuously produce butanol between 3.8 and 7.1 g/L for 16 days. While the concentration of butanol was slightly lower than the concentration

found in similar media in batch conditions, the constant flow of media through the culture increased the productivity due to the increased volume of media used. The productivity of butanol in an active volume of 2L under batch conditions in 96 hours would be 0.053 g/(L*hr), whereas the productivity of butanol under continuous fermentation was 0.22 g/(L*hr), showing a four-fold increase in productivity. The concentration (13.4 g/L) and productivity (0.40 g/(L*hr)) of butanol were nearly doubled by immobilizing the cells on porous polyvinyl alcohol.

Napoli et al. (2010) reported that Tygon rings in a 250 ml packed bed bioreactor promoted *Clostridium acetobutylicum* biofilm formation for a continuous fermentation of lactose. Using 30 g/L lactose medium under a continuous flow with a dilution rate of 0.97 h⁻¹ gave a butanol output of 4.59 g/L with a high selectivity over ethanol and acetone. The pH of the media was higher at a lower substrate concentration and flow rate, showing that the bacteria preferred to produce butyric acid over butanol when less sugar was available for fermentation. The productivity of butanol was maximized at 4.43 g/(L*hr).

Another study involving continuous fermentation using immobilized cells of *Clostridium acetobutylicum* immobilized onto sterilized cotton towels fermented glucose and xylose to produce butanol and acetone in high concentrations (Chen et al. 2013). Using concentrations of 60 g/L glucose, 60 g/L xylose and 30 g/L of each, the butanol concentrations produced by immobilized cells were 12.3 g/L, 10.03 g/L and 11.1 g/L, respectively. Using suspended cells rather than immobilized cells gave butanol concentrations of 9.58 g/L, 8.48 g/L and 8.65 g/L, respectively for each fermentation substrate. The maximum productivity of butanol using glucose on immobilized cells was 0.308 g/(L*hr) when using 60 g/L glucose, whereas maximum productivity of butanol using xylose was 0.223 g/(L*hr) using 30 g/L xylose. It was noted that

the suspended cells produced higher amounts of acetoin. Table 6 shows results from various research using continuous cultures in ABE fermentation.

Table 6 Various Results from Continuous Fermentation

Species	Carbon Source	Conditions	Yields (g/L)	Butanol Productivity (g/(L*hr))	Source
<i>C. beijerinckii</i> DSM 6423	Glucose (58.3 g/L)	Continuous fermentation at 37°C	Butanol – 4.48 2-Propanol – 3.40	0.267	Survase et al. 2011
<i>C. beijerinckii</i> DSM 6423	Glucose (58.3 g/L)	Continuous fermentation at 37°C with wood pulp immobilization matrix	Butanol – 6.1 2-Propanol – 4.8	3.09	Survase et al. 2011
<i>C. beijerinckii</i> DSM 6423	Glucose, mannose, arabinose, galactose, xylose (47.8 g/L total sugar)	Continuous fermentation at 37°C with no immobilization matrix	Butanol – 4.1 2-Propanol – 1.5	Not shown	Survase et al. 2013
<i>C. beijerinckii</i> DSM 6423	Glucose, mannose, arabinose, galactose, xylose (47.8 g/L total sugar)	Continuous fermentation at 37°C with coconut fiber immobilization matrix	Butanol – 8.6 2-Propanol – 5.9	Not shown	Survase et al. 2013
<i>C. beijerinckii</i> DSM 6423	Glucose, mannose, arabinose, galactose, xylose (47.8 g/L total sugar)	Continuous fermentation at 37°C with wood pulp immobilization matrix	Butanol – 10.3 2-Propanol – 6.1	Not shown	Survase et al. 2013
<i>C. beijerinckii</i> DSM 6423	Glucose, mannose, arabinose, galactose, xylose (47.8 g/L total sugar)	Continuous fermentation at 37°C with wood chip immobilization matrix	Butanol – 9.5 2-Propanol – 4.9	Not shown	Survase et al. 2013

Table 6 (Continued)

Species	Carbon Source	Conditions	Yields (g/L)	Butanol Productivity (g/(L*hr))	Source
<i>C. beijerinckii</i> DSM 6423	Glucose, mannose, arabinose, galactose, xylose (47.8 g/L total sugar)	Continuous fermentation at 37°C with sugarcane bagasse immobilization matrix	Butanol – 9.5 2-Propanol – 5.1	Not shown	Survase et al. 2013
<i>C. beijerinckii</i> DSM 6423	Glucose, mannose, arabinose, galactose, xylose (47.8 g/L total sugar)	Continuous fermentation at 37°C with wood pulp immobilization matrix	Butanol – 10.3 2-Propanol – 5.9	5.58	Survase et al. 2013
<i>C. beijerinckii</i> NCIMB 8052	Glucose (30 g/L)	Continuous culture at 37°C with 18mM added butyrate, free cells	Butanol – 7.1 Total ABE – 9.4	0.22	Lee et al. 2008
<i>C. beijerinckii</i> NCIMB 8052	Glucose (30 g/L)	Continuous culture at 37°C with 18mM added butyrate, immobilized cells on polyvinyl alcohol	Butanol – 13.4 Total ABE – 22.1	0.40	Lee et al. 2008
<i>C. acetobutylicum</i>	Lactose (30 g/L)	Continuous culture in a packed bed reactor at 35°C.	Acetone – 0.05 Butanol – 4.59 Ethanol – 0.55	4.43	Napoli et al. 2010
<i>C. acetobutylicum</i>	Glucose (30 g/L)	Continuous fermentation using suspended cells	Acetone – 1.75 Butanol – 6.59 Ethanol – 0.45	0.188	Chen et al. 2013
<i>C. acetobutylicum</i>	Glucose (60 g/L)	Continuous fermentation using cells immobilized on cotton towel	Acetone – 5.46 Butanol – 12.3 Ethanol – 1.6	0.308	Chen et al. 2013

Table 6 (Continued)

Species	Carbon Source	Conditions	Yields (g/L)	Butanol Productivity (g/(L*hr))	Source
<i>C. acetobutylicum</i>	Xylose (30 g/L)	Continuous fermentation using suspended cells	Acetone – 1.50 Butanol – 6.81 Ethanol – 0.126	0.124	Chen et al. 2013
<i>C. acetobutylicum</i>	Xylose (30 g/L)	Continuous fermentation using cells immobilized on cotton towel	Acetone – 1.62 Butanol – 6.93 Ethanol – 0.154	0.223	Chen et al. 2013
<i>C. saccharobutylicum</i>	Molasses (40 g/L total sugars)	Semicontinuous fermentation with suspended cells	Total ABE – 15.27	1.05 (ABE)	Ni et al, 2012

Coextraction of Butanol

Because butanol production is limited to concentrations of about 13 g/L due to the toxicity of the butanol produced in during fermentation, a way to boost yield is by using a coextractant to remove the butanol while fermentation takes place. The amphiphilic, yet slightly hydrophobic nature of butanol allows for a nonpolar solvent to extract the butanol from the aqueous solution. A good in-situ coextractant for butanol must not only readily pull butanol from an aqueous solution, allow for inexpensive separation of the butanol from the coextractant and be non-toxic to the bacteria (Adhami et al. 2009). Decanol is known to be a good extractant for butanol, but is toxic to *Clostridia* species (Evans and Wang, 1988). However, when a mixture of 20% decanol and 80% oleyl alcohol was added to the media during fermentation, solvent production by *Clostridium acetobutylicum* was increased by 72%. This showed that using a coextractant to continuously remove butanol during fermentation was able to boost yields far beyond the level of toxicity to the organism.

Biodiesel is a nonpolar solvent that is nontoxic to both the environment and solventogenic *Clostridia*, and the glycerol waste product generated during the production of biodiesel may also be used as a feedstock to some solventogenic strains (Adhami et al. 2009). It would therefore be theoretically possible for a fermentation of glycerol by *Clostridium pasteurianum* with biodiesel coextraction to not only utilize the glycerol waste to create fuel, but the butanol would not necessarily need to be removed if biodiesel was used as a coextractant. The removal of butanol via distillation could be used to separate butanol from biodiesel, but since both are to be utilized as fuel, that separation would not be necessary.

While nonpolar organic solvents can allow diffusion and removal of butanol from the aqueous phase, amphiphilic surfactants can bind more tightly with butanol within the solution, further decreasing the amount of butanol present in the aqueous phase. The polar and nonpolar ends of both the butanol and surfactant within aqueous media can form micelles and remove the butanol from the aqueous solution so the toxicity to the bacteria is reduced. The use of 6% L62 surfactant in a fermentation of 35 g/L of glucose by *Clostridium pasteurianum* is able to increase butanol production from 5.1 g/L to 10.4 g/L in comparison to a control batch with no surfactant (Dhamole et al. 2012).

In-situ removal of butanol from aqueous media does not necessarily need to be done by polar liquids. Vacuum filtration can help utilize the slightly volatile nature of butanol to remove it from fermentation media to help decrease the butanol concentration below the level of toxicity to the organism. Mariano et al. (2012) found that by using vacuum filtration through a condenser kept at 4°C, a 7L batch fermentation of 60 g/L of glucose using *Clostridium beijerinckii* could produce 106 g of butanol and 132.4 g of total ABE as opposed to the control batch which produced 80.6 g of butanol and 110.1 g of total ABE. The increase of 23.4 g of butanol and 22.3

g of total ABE shows that in-situ vacuum filtration not only increases butanol production by over 31%, but also increases the purity of butanol in the final product. Table 7 shows various results from fermentations using coextraction.

Table 7 Results from Batch Fermentations Using *in-situ* Product Removal

<i>C. acetobutylicum</i>	Glucose (70 g/L)	Batch fermentation at 34°C with pH controlled at 4.5	Butanol – 6.4	Evans and Wang, 1988
<i>C. acetobutylicum</i>	Glucose (70 g/L) plus 1% (vol/vol) butyric acid	Batch fermentation at 34°C with pH controlled at 4.5, mixed with 5% of decanol/oleyl alcohol	Butanol – 16.3	Evans and Wang, 1988
<i>C. acetobutylicum</i> DSM 792	Glucose, Xylose, Arabinose, Galactose and Mannose (60 g/L total)	Two-stage continuous fermentation at 37°C with <i>in situ</i> product removal using oleyl alcohol/decanol (4:1)	Acetone – 4.93 Butanol – 13.58 Ethanol – 1.80	Bankar et al, 2013
<i>C. pasteurianum</i>	Glucose (35 g/L)	Batch fermentation at 32°C	Butanol – 5.1 Acetone – 1.8	Dhamole et al. 2012
<i>C. pasteurianum</i>	Glucose (35 g/L)	Batch fermentation at 32°C with 6% L62 surfactant added	Butanol – 10.4 Acetone – 3.7	Dhamole et al. 2012
<i>C. beijerinckii</i> NCIMB 8052	Glucose (60 g/L)	Batch fermentation at 35°C	Acetone – 26.6g Butanol – 80.6g Ethanol – 2.9g	Mariano et al. 2012
<i>C. beijerinckii</i> NCIMB 8052	Glucose (60 g/L)	Batch fermentation at 35°C with vacuum filtration	Acetone – 23.5g Butanol – 106g Ethanol – 2.9g	Mariano et al. 2012

III. MATERIALS AND METHODS

Microorganism

Clostridium beijerinckii optonii was obtained from the Centralbureau voor Schimmelcultures, Utrecht, Netherlands. Its code number is NCCBNr 84049 and it has a tentative identification as *Clostridium sp.* Prazmowski 1880 AL. It is cross listed as ATCC 27022, NCIB 12605 and strain N1-504. The original isolation was from soil in Japan. It is listed as a source for production of 1-butanol and acetone in US Patent 2,945,786. The organism was reclassified as *Clostridium saccharoperbutylacetonium* (Shaheen et al. 2000).

Organism Identification. The classification of the organism that was received was checked by running a carbon source utilization profile. The carbon sources tested, in duplicate, were glucose, fructose, sucrose, arabinose, xylose, mannose, cellobiose, sorbitol and galactose. Growth medium [20 ml] were placed in 25 ml test tubes. The media, made in duplicate for each carbon source tested contained 40 g/L of carbon source, 5.0 g/L proteose peptone3 [Difco, Sparks, MD], 5.0 g/L yeast extract [Fluka, St. Louis, MO], 5.0 g/L monobasic potassium phosphate [Sigma, St. Louis, MO], 5.0 g/L sodium thioglycolate [Sigma, St. Louis, MO] and adjusted to pH 6.5 with sodium hydroxide [Fisher, Pittsburg, PA]. The test tubes were autoclaved at 121°C for 20 minutes before inoculation with 2 ml of prepared inoculum. The test tubes were placed in a shaking incubator at 36°C for 48 hours and growth was determined.

Preparation and Storage of Inocula

Clostridium medium (5 g/l glucose, 5 g/l proteose peptone3, 5 g/l yeast extract, 5 g/l sodium thioglycolate and 5 g/l monobasic potassium phosphate and 0.002 g/L methylene blue [MCB, Norwood OH], adjusted to pH 6.5 with dilute sodium hydroxide) was dispensed into 9 and 120 ml vials with adequate headspace to accommodate inocula and capped with butyl rubber

stoppers. A syringe with 26 gauge needle was used to create a vacuum in the vials in order to reduce risk of the stopper coming off the bottles while autoclaving.

Clostridium beijerinckii optonii spores (200 µl) were heated for 10 min at 80°C followed by cooling to room temperature on ice. The heat shocked spores (100ul) were inoculated into 900 ul of Clostridium medium in 1.5 ml Eppendorf centrifuge tubes. The spore suspensions were allowed to grow inside an anaerobic chamber for 24 hours in an incubator at 36 °C. A GasPak anaerobic sachet was used to remove oxygen within the anaerobic chamber. Inocula (1.0 ml) were then transferred to 7 ml of Clostridium media in a 9 ml vial as described above. After 18-24 hours in a shaking incubator at 36°C, this suspension was transferred to 100 ml of media and allowed to grow anaerobically in a shaking incubator for 18 to 24 hours.

The *Clostridium beijerinckii optonii* culture was stored on pour plates at 4 °C and transferred every every 2 to 3 months and used as a source of inocula, eliminating the need to heat shock spore before each use. The plates contained 5.3 grams of Brewer agar [Sigma, St. Louis, MO] per 100 ml of distilled water. Inoculated cultures were grown on plates in a GasPak anaerobic sachet. After growth in an incubator at 36°C for 36 to 48 hours, the cultures were transferred to a refrigerator where they were kept for up to 6 months. Individual colonies were used to inoculate 1.5 ml Eppendorf tubes. Cultures were also preserved by storage in 10% glycerin at -20°C. After growth in 100 ml of media in 120 ml vials, the cultures were centrifuged in 2 ml Eppendorf tubes for 10 minutes at 3000 RPM using an Eppendorf 5415D centrifuge. The supernatant fluid was removed from the centrifuge tubes and the cell pellet was transferred from 5 tubes and added to 0.9 ml of 20% glycerin. These cultures were stored in the freezer at -20 °C for up to 2 years.

Growth and Production Conditions

Determination of Optimal Growth Temperature. Test tubes [30 ml] containing of 22.5 ml of *Clostridium* media were inoculated with 2.5 ml of inocula and incubated at 32 °C, 34 °C, 36 °C, 38 °C or 40 °C for 14.5 hours. The absorbance (660nm) for each culture was measured using a SP6 Series Model 350 [Pye Unicam, Cambridge, England] UV and Visible spectrophotometer at 60 minute intervals to determine the time required for growth to reach stationary phase.

Solvent Toxicity. To determine what concentrations of acetone or 2-propanol is toxic to *Clostridium beijerinckii optonii*, 100 ml vials of *Clostridium* media were prepared with 1.0, 2.0, 3.0 or 4.0 ml of added acetone or 2-propanol. Prepared inocula [6 ml] were added to each test vial. The control had no added solvent. Growth was determined at 24 hours and 48 hours.

Batch Fermentations

Batch fermentations (1.5 L) in 3 L vessels were performed using a New Brunswick [New Brunswick, NJ] Bioflo fermenter/bioreactor. Fermentation conditions included a flow of nitrogen at 8 ml/min, 36 °C, 150 rpm agitation. Fermentation was performed in media containing 30 g/L glucose with different concentrations of $\text{FeSO}_4 \cdot 7\text{H}_2\text{O}$ [0.5 to 2.0 mg/L] in P2 media. Fermentations were also conducted using sugarcane juice and sugarcane molasses media. The sugarcane juice medium was made with 500 ml sugarcane juice (roughly 12.4 brix) per liter medium to bring the total fermentable sugar concentration to 54.3 g/L and the P2 stock solutions listed below, with the volume made to 1.5 L with water. The molasses medium was prepared similarly using 77 g/L molasses to bring the fermentable sugar concentration to 38.5 g/L. Tryptone, 1 g/L and yeast extract, 1 g/L were added to each media. Filter-sterilized 10 ml/L of P2 stock solutions [(buffer: KH_2PO_4 , 50 g/L; K_2HPO_4 [Sigma, St. Louis, MO], 50 g/L;

ammonium acetate [Sigma, St. Louis, MO], 220 g/L), (vitamins: para-amino-benzoic acid [Sigma, St. Louis, MO], 0.1 g/L; thiamin [Sigma, St. Louis, MO], 0.1 g/L; biotin [Sigma, St. Louis, MO], 0.001 g/L), and (minerals: $\text{MgSO}_4 \cdot 7\text{H}_2\text{O}$ [MCB, Norwood, OH], 20 g/L; $\text{MnSO}_4 \cdot \text{H}_2\text{O}$ [JT Baker, Phillipsburg, NJ], 1 g/L; $\text{FeSO}_4 \cdot 7\text{H}_2\text{O}$ [JT Baker, Phillipsburg, NJ], 1 g/L; NaCl [Fisher, Pittsburg, PA], 1 g/L)] (Qureshi and Blaschek, 1999) were added prior to inoculation.

During the course of fermentation, 2 mL samples were collected at 0 hours, 12 hours, 24 hours, 36 hours, 48 hours, 72 hours, 96 hours and 120 hours for molasses and juice media. The samples were used to measure glucose, sucrose, fructose, acetic acid, butyric acid, n-butanol, 2-propanol, ethanol and acetone were determined by HPLC and/or GC analysis for each sample. The organisms in each sample were photographed under a National 12V microscope [National Optical and Scientific Instruments, Inc, Schertz, TX] with Motic Images Plus 2.0 software [Motic, Hong Kong] for each of the juice samples. The pH of the media was monitored automatically by the fermenter unit at 12 minute intervals throughout the course of the fermentations. Samples [6 ml] were taken from the glucose media at 0 hours, 8 hours, 16 hours, 24 hours, 36 hours, 48 hours, 72 hours and 96 hours. The absorbance at 660 nm of each sample was determined using a DU series 800 UV and visible spectrophotometer [Beckman and Coulter, Fullerton, CA].

Butanol Coextraction

An additional batch fermentation using glucose (55 g/L) medium was performed with an addition of 20% soybean oil for coextraction. Samples [2 ml] were drawn at 0, 96 and 144 hours and measured for glucose, acetone, ethanol, 2-propanol and butanol.

Immobilized Cell Column

A 300 ml jacketed immobilized cell column was constructed using inoculated porous ceramic Raschig rings [Brewhaus, Keller, TX]. The ceramic Raschig rings [720 g] were washed with 2 changes of 400 ml each distilled water autoclaved and then placed in a solution of 10% glucose for 72 hours, to allow the sugar to permeate into the pores of the ceramic. The glucose solution was drained and the Raschig rings were poured into a sterilized column set-up. An inoculum [220 ml of glucose limited stationary phase culture in *Clostridium* media] was added and allowed to sit for 24 hours. The column was started using 30 g/L glucose media with P2 supplementation. The column temperature was maintained at 36°C using a circulating water bath. The entire apparatus is shown in Figure 4. An airlock (Figure 5) was placed between the media reservoir and the pump in order to prevent back contamination from the column to the reservoir. The feed was in an upward direction through the immobilized column (Figure 6) using a Cole-Parmer Masterflex pump model 77201-62. The spent media was collected in a reservoir after the column. A Y-split in the tubing, post-column, allowed for sampling after the media passed through the column. Solvent production and sugar consumption was monitored daily and flow rates were altered in order to determine the optimum flow rate for solvent production. Samples were examined under microscope to determine purity of the culture. If significant contamination occurred, the column was heated to 75 °C for 15 minutes and then allowed to incubate for 24 hours so the *Clostridium beijerinckii optonii* culture could reestablish dominance.

Analytical Procedures

Solvent concentrations (butanol, isopropanol, acetone, ethanol) and acids (acetic and butyric) were determined using an Agilent 7890A Gas Chromatography System [Agilent Technologies, Santa Clara, CA]. The injection size was 1.0 µL into a Zebron ZB Waxplus

[Phenomenex, Torrance, CA] capillary GC column, 60 m x 0.25 mm ID with 0.25 μ m film thickness. The injection was split 40:1 with a flow of 1.4 ml/min through the column. Initial temperature of 35 °C was held for one minute, then raised by 10 °C/min up to 150 °C, held for ten minutes, raised by 10 °C/min up to 180 °C, held for five minutes and lowered by 40 °C/min to 35 °C for a total run time of 34.125 minutes. The analytes were determined with a flame ionization (FID) detector [Agilent Technologies, Santa Clara, CA] held at 280 °C.



Figure 4 Immobilized culture apparatus flowing with 3.5% glucose medium. Silicon tubing, 0.0625" I.D. x 0.125" O.D. inside 0.125" I.D. x 0.25" O.D. near the pump and 0.188" I.D x 0.313" O.D. around the rest of the apparatus was used



Figure 5 Airlock used to avoid back-contamination of media reservoir



Figure 6 Immobilized cell column filled with ceramic Raschig rings

Standards for acetone [Macron, Center Valley, PA] (0.10013%, 0.250325%, 0.50065% and 1.0013%), 2-propanol [Mallinckrodt, Phillipsburg, NJ], (0.10024%, .02506%, 0.5012% and 1.0024%), ethanol [Pharmco AAPER, Shelbyville, KY] (0.10006%, 0.25015%, 0.5003% and 1.0006%), n-butanol [Alfa Aesar, Ward Hill, MA], (0.10002%, 0.25005%, 0.5001% and 1.0002%), acetic acid [Mallinckrodt, Phillipsburg, NJ] (0.10030%, 0.25075%, 0.5015% and 1.0030%) and butyric acid [Aldrich, Milwaukee, WI] (0.100347%, 0.25087%, 0.50173% and 1.00347%) were made for each analyte tested using the gas chromatograph.

Sugars were analyzed using Agilent 1200 series [Agilent Technologies, Santa Clara, CA] HPLC and a Bio-Rad HPLC Carbohydrate Analysis Aminex® HPX-87K column [Bio-Rad Laboratories, Philadelphia, PA] with a water mobile phase running at 0.6 ml/min. The column was set at 85 °C for a 40 minute run time and an injection of 20 µl. Sugars were measured using a refractive index detector (RID) [Agilent Technologies, Santa Clara, CA]. Standards of glucose [NIST, Gaithersburg, MD] (0.89%, 2.96% and 5.91%), fructose [Sigma, St. Louis, MO] (0.88%, 2.91% and 5.83%) and sucrose [NIST, Gaithersburg, MD] (10.09%, 20.01% and 30.04%) were used to make the standard curve for each sugar using the HPLC.

Statistical and Experimental Design

The optimization of growth temperature was tested with single cultures at each temperature as each culture had a slightly different initial absorbance and lag phase. The experiment was run in duplicate, on two separate occasions. The sugar fermentation tests as well as the solvent toxicity tests were run in duplicate. Each of the batch cultures were single trials. Duplicate trials were conducted on the P2 media containing 0.5 mg/L $\text{FeSO}_4 \cdot 7\text{H}_2\text{O}$ and 2.0 mg/L $\text{FeSO}_4 \cdot 7\text{H}_2\text{O}$ to assure repeatability of the tests.

The 95% confidence intervals in the summary of the effects of iron on fermentation were determined using two-tailed T test. The probability of comparing percentages of solvents formed in normal pH and low pH fermentations was determined using a paired T test.

The immobilized culture with 25 g/L glucose medium was run at each flow rate for one week. The culture was allowed to run for 48 hours before the first sample was taken. Samples (5 mL) from the immobilized culture were taken daily. Each sampling was done in triplicate unless otherwise stated.

IV. RESULTS

Optimization of Temperature

The growth of *C. beijerinckii optonii* in Clostridium media, measured by the absorbance at 660 nm showed that the maximum growth occurred within 8 hours for cultures incubated between 34°C and 36°C. Stationary phase was delayed at temperatures above and below 36°C and growth was relatively slower. By giving a logarithmic value to the corrected absorbance, the curves for the logarithmic growth phase for each culture were transfigured into straight lines.

Figure 7 shows the natural log of the corrected absorbance at 660 nm as a function of temperature.

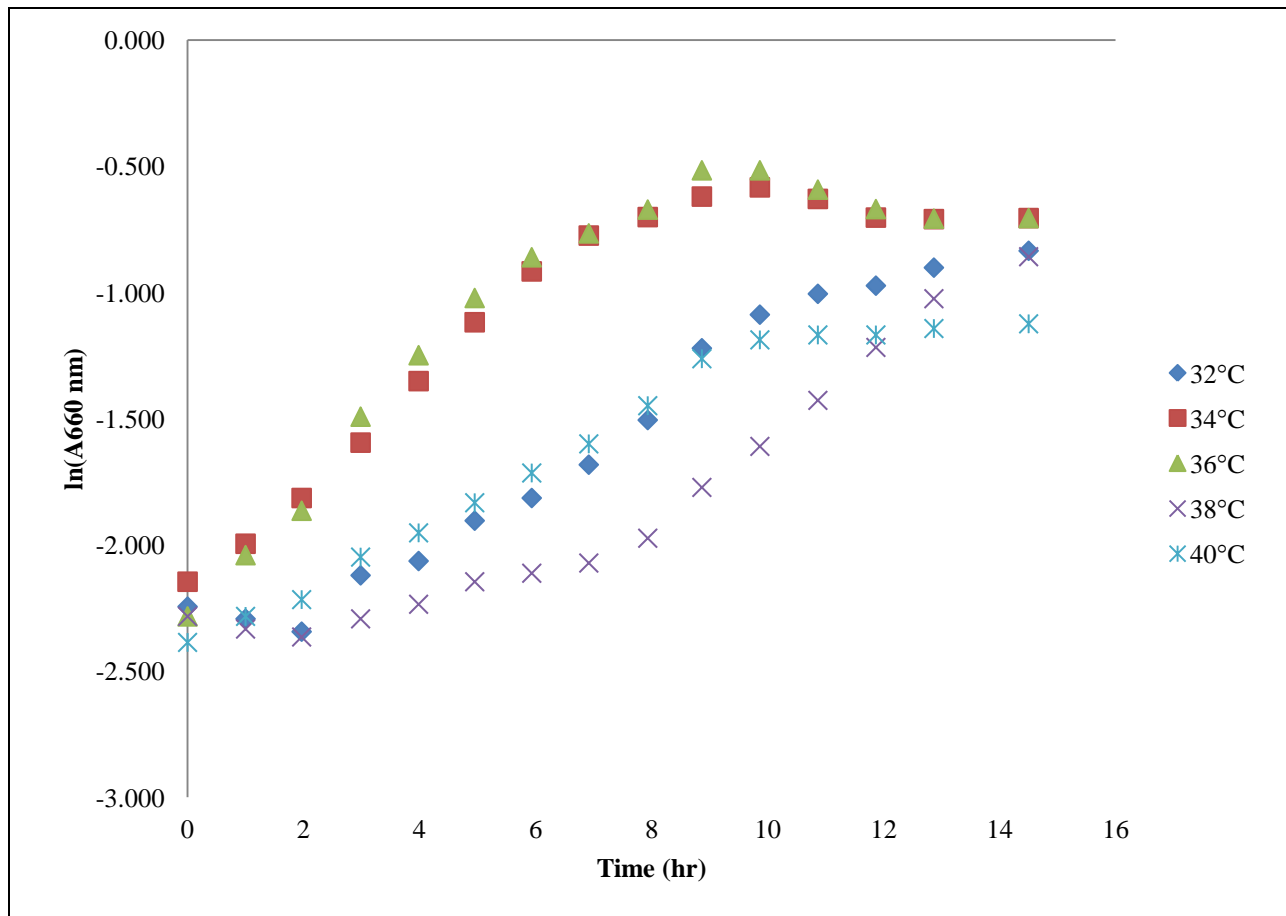

Figure 7 Growth curves transfigured to the natural log of the absorbance at 660 nm as a function of temperature. The stationary growth phase is determined by the intervals where the function shows a straight line

The doubling rate, as measured by the slope of the natural log of the absorbance at 660 nm over time during log phase, showed that the fastest doubling rate was achieved at 36 °C with 0.253 doublings per hour. Figure 8 shows the doubling rate of *C. beijerinckii optonii* at temperatures ranging from 32 ° to 40 °C.

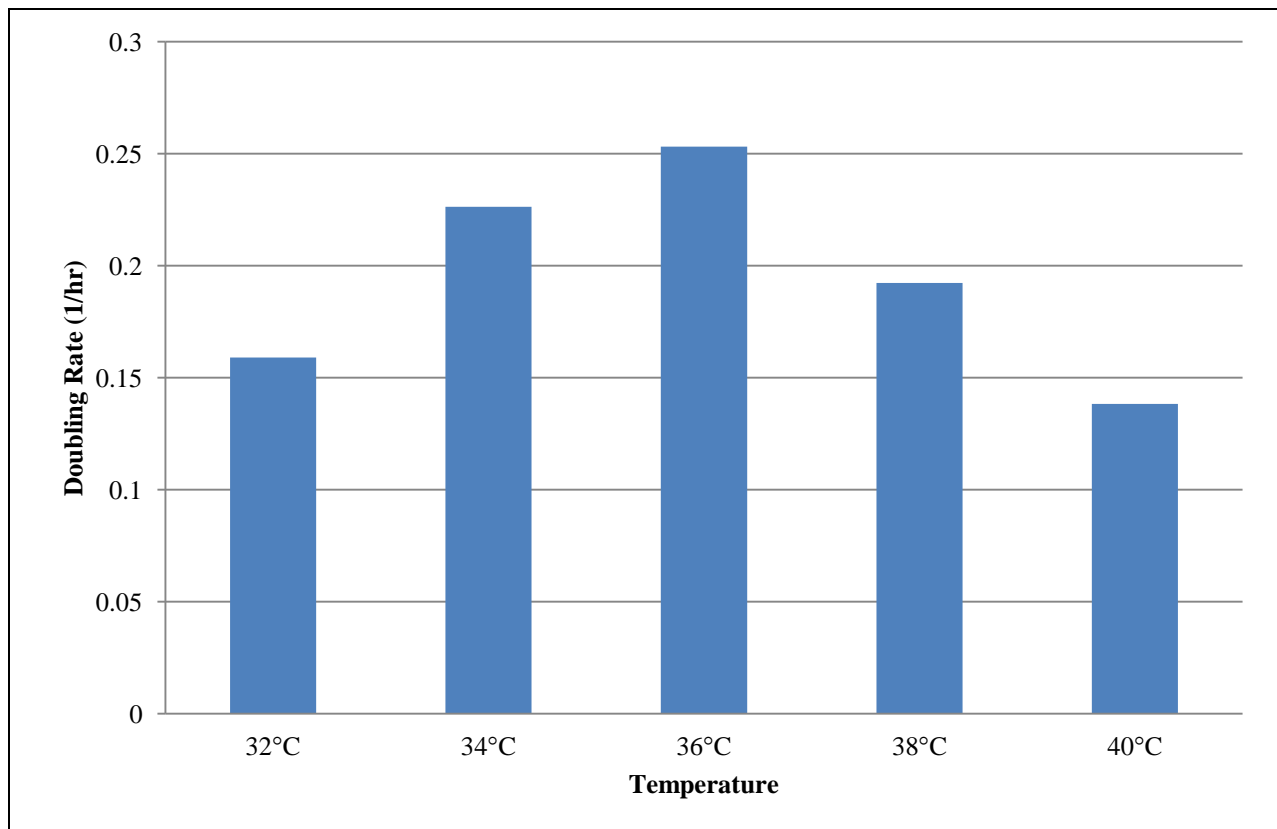

Figure 8 Doubling rate during logarithmic growth phase of *C. beijerinckii optonii* at different temperatures. Optimal growth temperature was 36 °C

Sugar Fermentation Test

The bacteria were able to ferment mannose, galactose, sorbitol, glucose, fructose, sucrose, cellobiose and slight growth was seen on arabinose. No growth was seen with xylose as a carbon source or in the absence of any simple carbohydrate. The ability to ferment glucose, mannose and cellobiose matches the reports for *Clostridium saccharoperbutylacetonicum* N1-4, *C. saccharoperbutylacetonicum* N1-504 and *C. beijerinckii* (Sneath et al, 1986). The ability to

ferment galactose suggests that this bacterium could be more closely related to *C. beijerinckii* than *C. saccharoperbutylacetonicum*. The achieved and expected results are shown in Table 8.

Table 8 Carbon Sources Fermented by *C. saccharoperbutylacetonicum*, *C. beijerinckii* and achieved results by *C. beijerinckii optonii*

Sugar	Expected results (Kies et al. 2001)			Achieved results
	<i>C. saccharoperbutylacetonicum</i> N1-4	<i>C. saccharoperbutylacetonicum</i> N1-504	<i>C. beijerinckii</i>	<i>C. beijerinckii optonii</i>
None	-	-	-	-
Mannose	+	+	+	+
Galactose	-	-	+	+
Sorbitol	+	-	Sl.*	+
Xylose	+	+	+	-
Glucose	+	+	+	+
Fructose	+	+	+	+
Sucrose	+	+	+	+
Arabinose	+	+	Sl.*	Sl.*
Cellobiose	+	+	+	+

*Sl. = slight

Based on these observations, the species used for this study was reclassified as *C. beijerinckii optonii*.

Solvent Toxicity

A control [Clostridium medium without added solvents] and a culture with 1% added acetone or 2-propanol showed growth after 24 hours indicating neither acetone nor 2-propanol were inhibitory at this concentration. Those cultures in the presence of 2% 2-propanol showed growth after 48 hours but did not grow in the presence of 2% acetone, 3% acetone and 3% 2-propanol.

Fermentation was not inhibited by 1% 2-propanol or 1% acetone. Fermentation was slowed, but not fully inhibited by 2% 2-propanol, whereas 2% acetone and 3% 2-propanol inhibited fermentation.

Production of Solvents on Glucose [P2 medium] with Varying $\text{FeSO}_4 \cdot 7\text{H}_2\text{O}$ Concentrations

Glucose Fermentation with 1.0 mg/L (3.6 μM) $\text{FeSO}_4 \cdot 7\text{H}_2\text{O}$. Fermentation on 31.1 g/L glucose in the presence of 1.0 mg/L $\text{FeSO}_4 \cdot 7\text{H}_2\text{O}$ had a lag phase of about 8 hours. Once rapid growth began, stationary phase was achieved in just over 36 hours.

The pattern that was seen in all fermentations was a fall in pH followed by pH increase as the acids were converted to solvents. After the initial lag, media pH dropped from 5.8 to 5.1 (Figure 9). The pH then rose and fell several times before settling around 5.10.

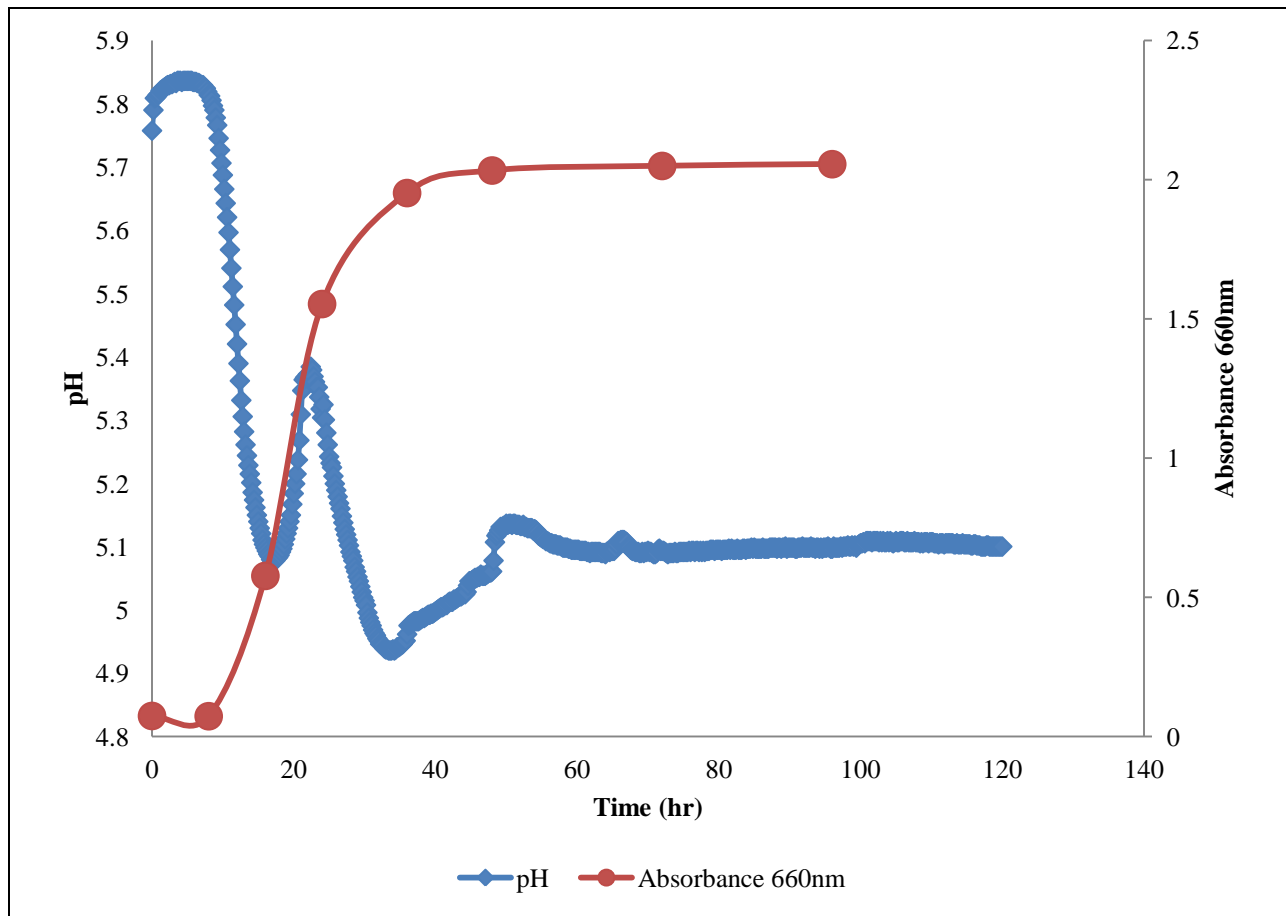

Figure 9 The pH during the fermentation of 31.1 g/L glucose with 1.0 mg/L $\text{FeSO}_4 \cdot 7\text{H}_2\text{O}$. The pH rose and fell twice before it settled at 5.1

Acetic and butyric acids decreased from 12.4 g/L to 2.6 g/L during the fermentation.

Solvents began to form around 8 hours into log phase and increased for the duration of the

fermentation. The majority of the glucose was consumed and solvent concentration increased until 48 hours post-inoculation (Figure 10).

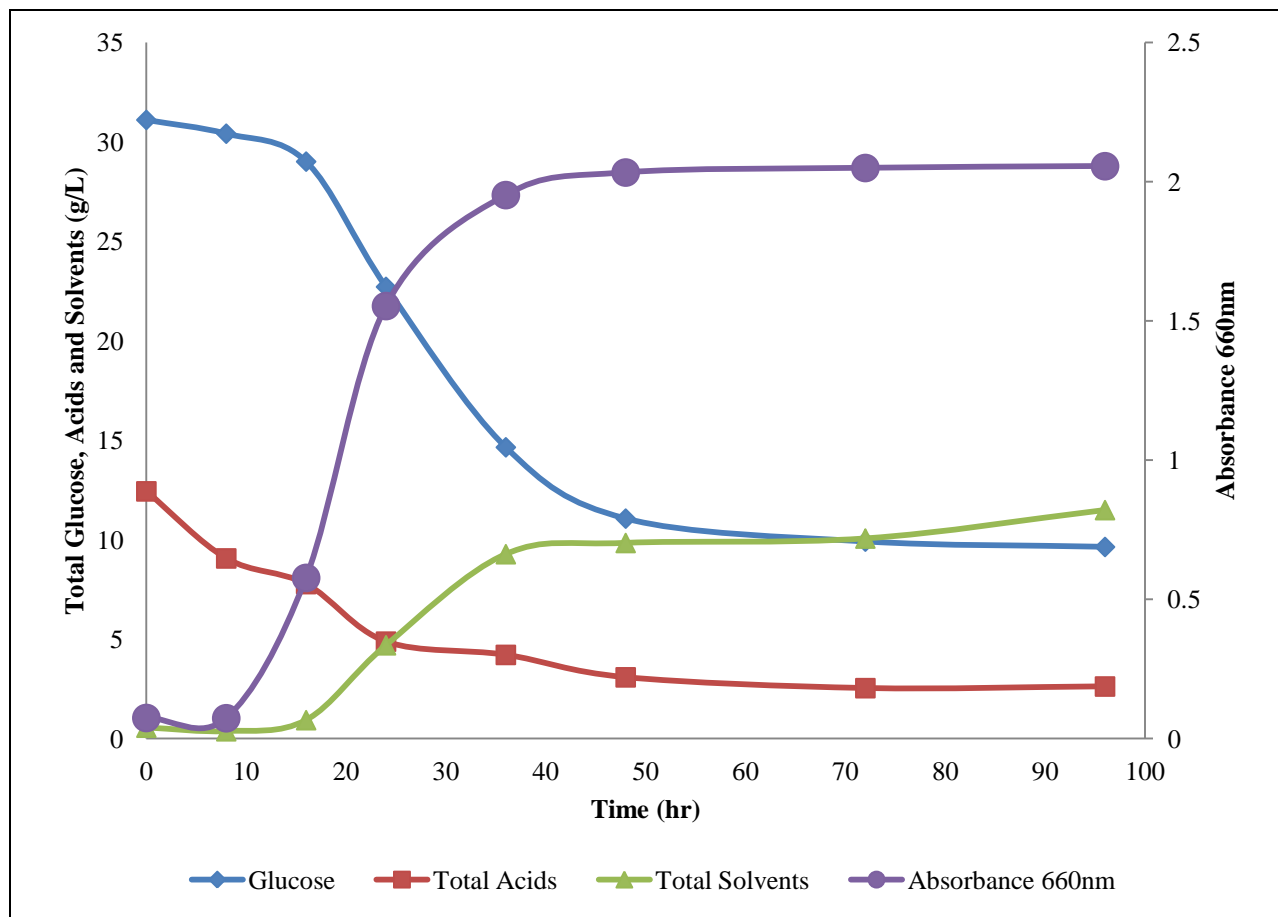

Figure 10 Totals of the glucose, total organic acids and total solvents during the fermentation of 31.1 g/L glucose with 1.0 mg/L $\text{FeSO}_4 \cdot 7\text{H}_2\text{O}$. Glucose concentration dropped from 31.1 g/L to 9.6 g/L. Acids, primarily acetic acid, dropped from 12.4 g/L to 2.6 g/L. Solvents totalled 11.5 g/L

After 48 hours, the acids and sugars had decreased from 3.1 g/L to 2.6 g/L and 11.1 g/L to 9.6 g/L, respectively matched with a small increase in total solvent concentration from 9.8 g/L to 11.5 g/L. The maximum concentration of solvents was obtained about 96 hours post-inoculation. Butanol comprised the majority (61%) of the solvent produced in the fermentation at 7.0 g/L. The fermentation also produced 3.8 g/L 2-propanol (33% of total solvents), 0.4 g/L ethanol (3% of total solvents) and 0.3 g/L acetone (3% of total solvents) as shown in Figure 11. The solvent production totalled 11.5 g/L in the 96 hour fermentation.

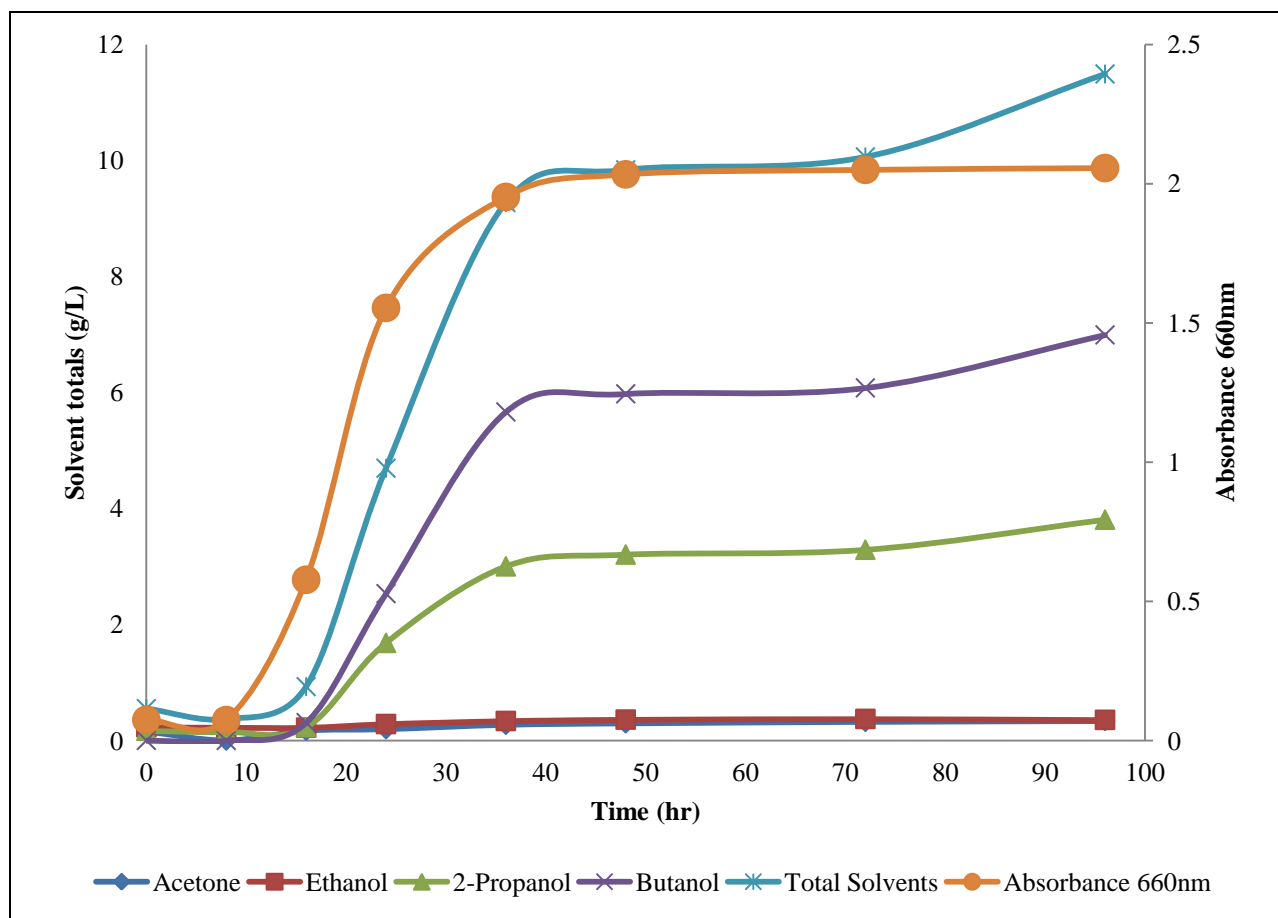

Figure 11 Formation of solvents during the fermentation of 31.1 g/L glucose with 1.0 mg/L $\text{FeSO}_4 \cdot 7\text{H}_2\text{O}$. Butanol production totalled 7.0 g/L, 2-propanol totalled 3.8 g/L, ethanol totalled 0.4 g/L and acetone totalled 0.3 g/L at 96 hours. Total solvents were 11.5 g/L

The fermentation of 31 g/L glucose required 21.5 g/L glucose to produce 7.0 g/L butanol and 11.5 g/L total solvents. The yield of butanol was 0.33 grams of butanol per gram of sugar utilized. The maximum productivity for butanol occurred at 36 hours post-inoculation as 0.16 g/L/hr.

The bacteria changed physically and morphologically during the course of the fermentation. The cells appeared as short bacilli for the first 8 hours. As the cells began to lengthen, the pH dropped and glucose consumption accelerated. The cells shortened as the pH rose and solvents formed. By 24 hours, spores had formed within the cells. As cells entered the death phase, they lysed and the spores were released into the medium. The number of actively

growing cells decreased as the number of spores increased. Microscopic images are shown in Figure 12.

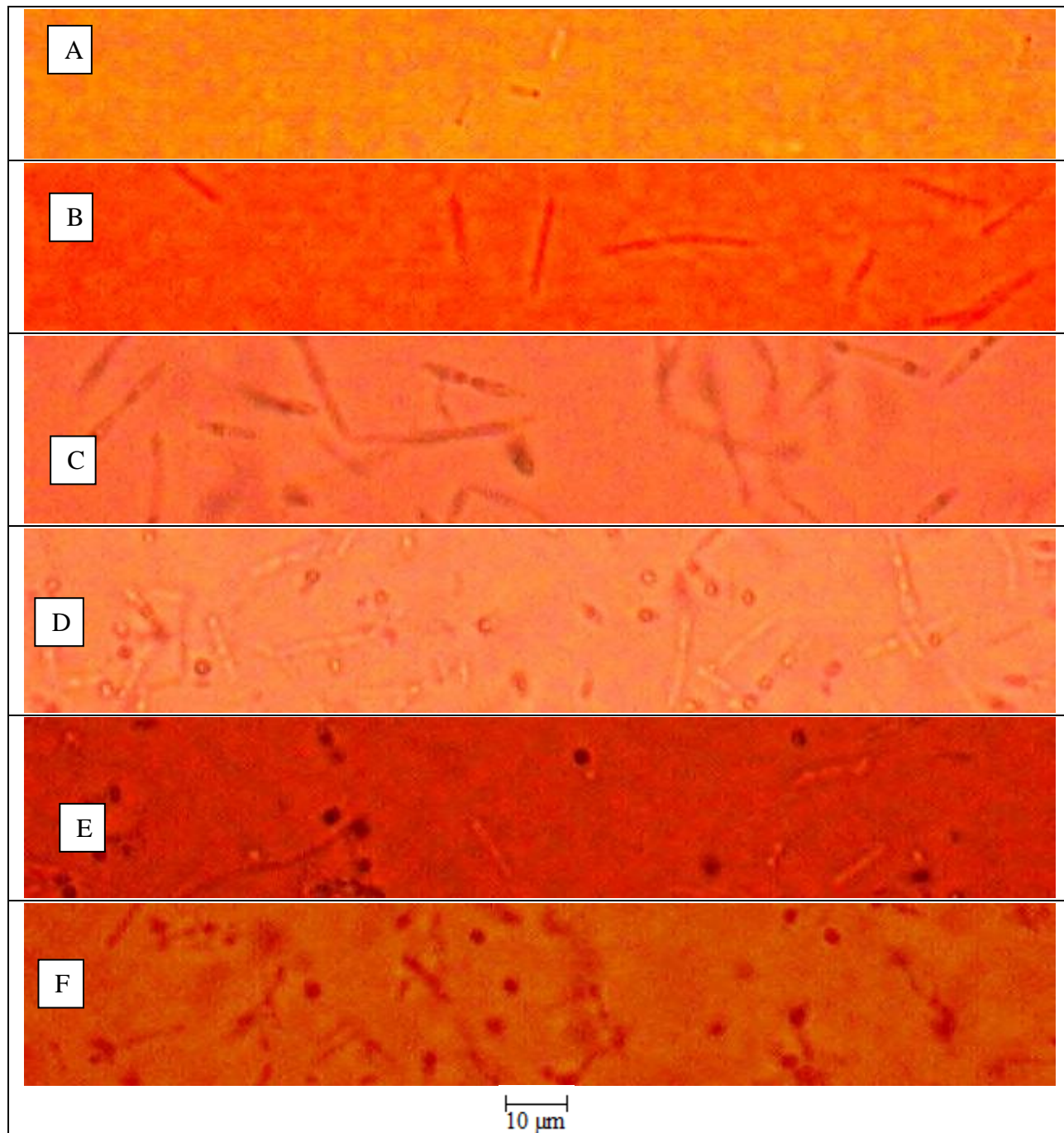

Figure 12 Microscopic images of *C. beijerinckii optonii* cultures grown in 31.1 g/L glucose medium with 1.0 mg/L $\text{FeSO}_4 \cdot 7\text{H}_2\text{O}$ at 8 hours (A), 16 hours (B), 24 hours (C), 36 hours (D), 48 hours (E) and 72 hours (F). Cells elongate at 16 hours and shorten at 24 hours. Spores develop at 24 hours and increase until 72 hours. Images beyond 72 hours are not shown as they were similar to the 72 hour sample

Glucose Fermentation with 1.5 mg/L (5.4 μ M) FeSO₄·7H₂O. The fermentation of 28.3 g/L glucose by *C. beijerinckii optonii* in P2 medium with an additional 0.5 mg/L FeSO₄·7H₂O behaved similarly to fermentations without the additional iron. As seen in fermentations without additional iron sulfate, the pH fluctuated over the course of the fermentation. There was a sharp drop from 6.1 to 5.2 followed with a few fluctuations with final pH settling at 4.9 from 42 hours until the end of the fermentation as shown in Figure 13.

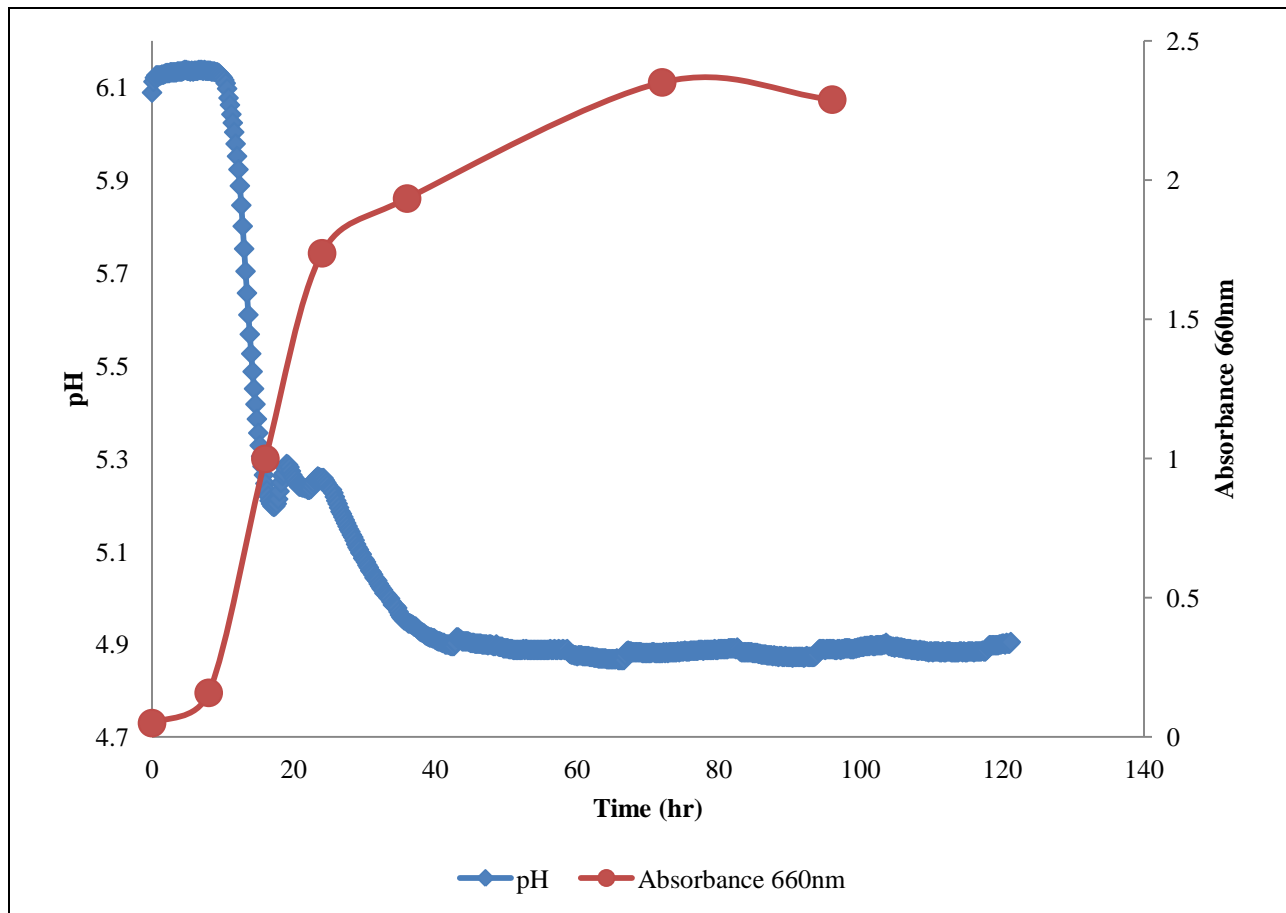

Figure 13 The pH of a fermentation of 28.3 g/L glucose with 1.5 mg/L FeSO₄·7H₂O. The pH dropped to 4.9 with two small peaks from 18 to 25 hours

The drop in pH between 8 and 17 hours did not correlate with the generation of acids as they decreased during that time. As with the fermentation of glucose without additional iron, the majority of glucose was consumed and solvents were produced by 48 hours (Figure 14).

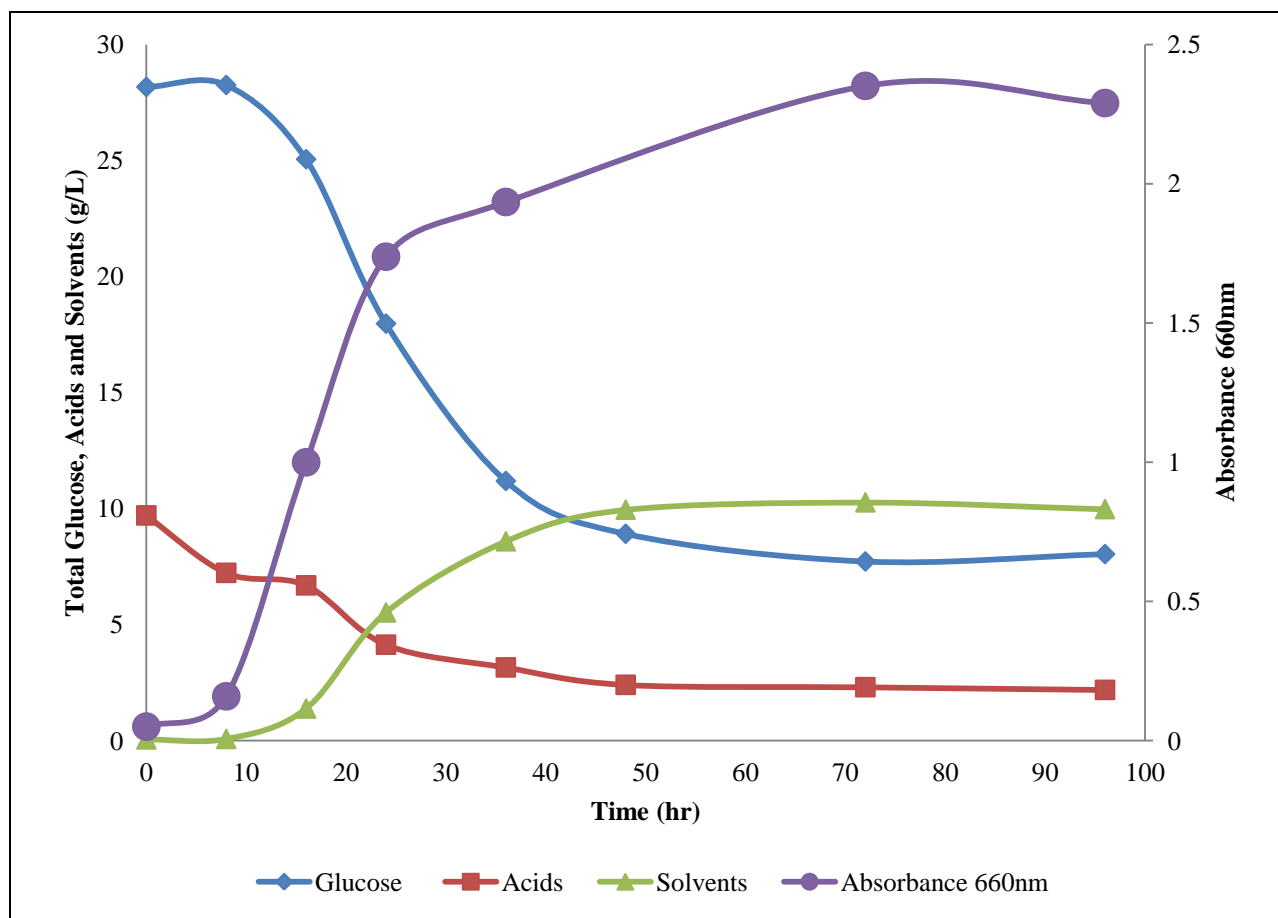

Figure 14 The total glucose, acids and solvents during a fermentation of 28.3 g/L glucose with 1.5 mg/L $\text{FeSO}_4 \cdot 7\text{H}_2\text{O}$. The glucose dropped from 28.3 g/L to 7.7 g/L, the total acids dropped from 9.7 g/L to 2.2 g/L and the total solvents reached 10.3 g/L

The maximum amount of solvents were produced at 72 hours when the totals of butanol, 2-propanol, ethanol and acetone were 6.3 g/L (61% of total solvents), 3.7 g/L (36% of total solvents), 0.2 g/L (2% of total solvents) and 0.2 g/L (2% of total solvents), respectively as shown in Figure 15. The solvent production totaled 10.3 g/L compared to 7.0 g/L with regular P2 medium.

The microscopic images of the fermentation of 28.3 g/L glucose in P2 medium with 0.5 mg/L additional iron sulfate were similar to those with lower iron levels. The cells elongated for the first 16 hours and spores formed at 24 hours. As the fermentation progressed, the number of free spores increased and the number of actively fermenting cells decreased. The microscopic images are shown in Figure 16.

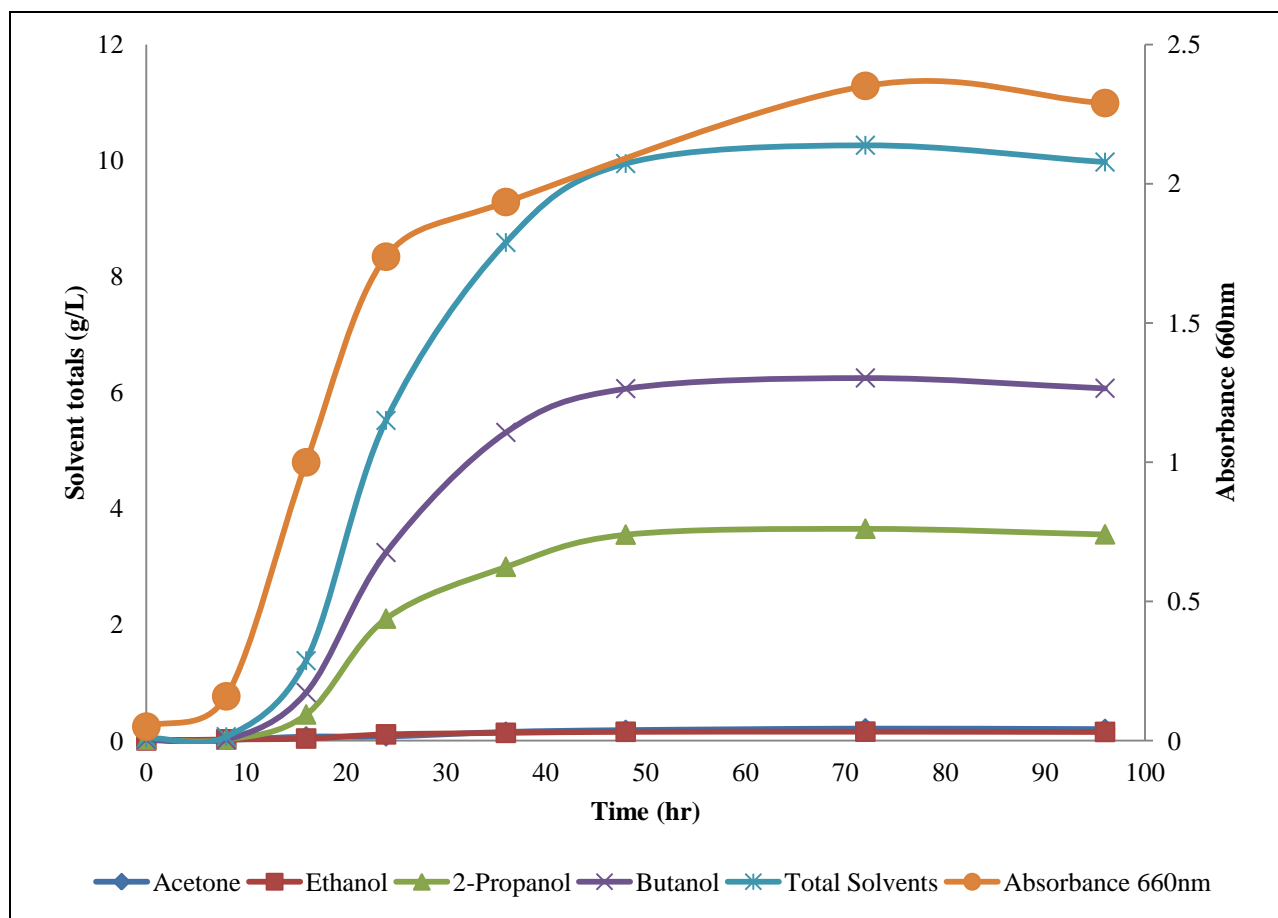

Figure 15 Concentration of solvents generated during the fermentation of 28.3 g/L glucose with 1.5 mg/L $\text{FeSO}_4 \cdot 7\text{H}_2\text{O}$. Total solvents reached 10.3 g/L at 72 hours. The concentration of butanol was 6.3 g/L, 2-propanol was 3.7 g/L, ethanol was 0.2 g/L and acetone was 0.2 g/L

This fermentation produced 6.3 g/L butanol. The yield of butanol was 0.304 grams of butanol per gram of sugar utilized in 72 hours. The maximum rate of productivity of butanol occurred at 36 hours of fermentation with a butanol productivity of 0.15 g/L/hr.

Glucose Fermentation with 2.0 mg/L (7.2 μM) $\text{FeSO}_4 \cdot 7\text{H}_2\text{O}$. The fermentations of 31.9 g/L glucose and 32.5 g/L glucose in P2 media plus additional 1.0 mg/L $\text{FeSO}_4 \cdot 7\text{H}_2\text{O}$ were similar to other glucose fermentations. Similar to the other fermentations of glucose, the pH rapidly dropped from 5.9 to 4.9 and had a few fluctuations before stabilizing and settling around 5.4 (Figure 17).

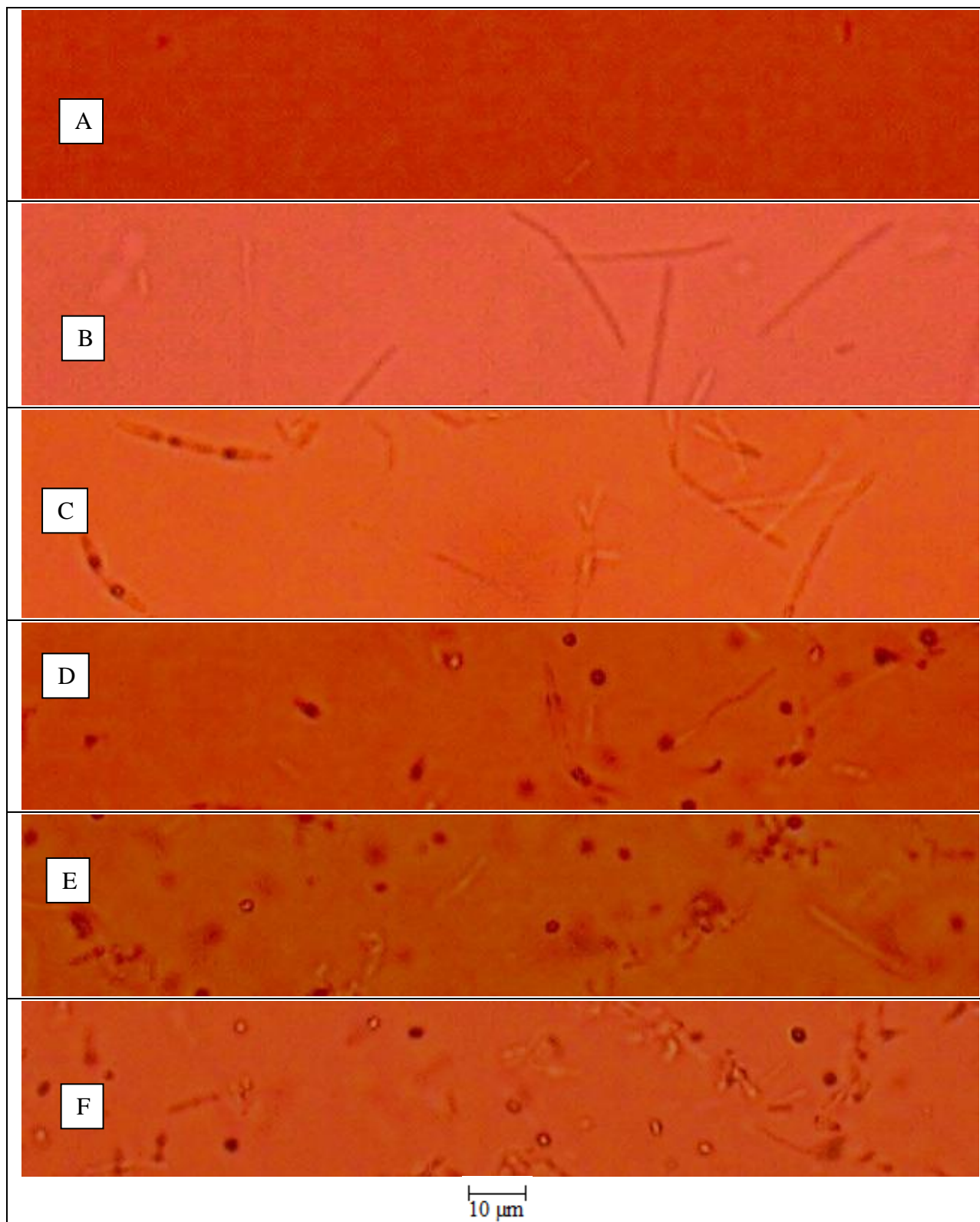

Figure 16 Microscopic images of *C. beijerinckii optonii* culture grown in 28.3 g/L glucose medium with 1.5 mg/L $\text{FeSO}_4 \cdot 7\text{H}_2\text{O}$ at 8 hours (A), 16 hours (B), 24 hours (C), 36 hours (D), 48 hours (E) and 72 hours (F)

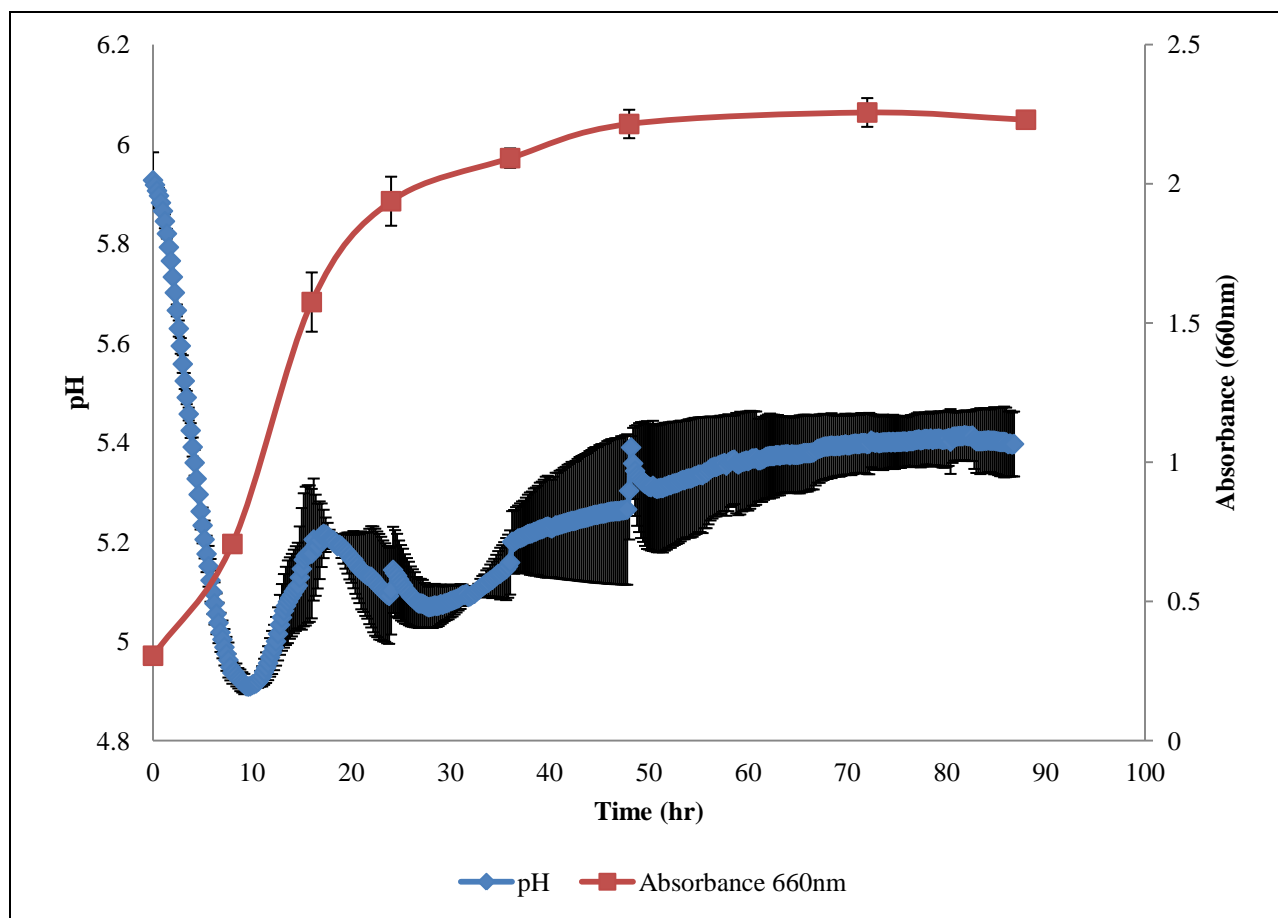

Figure 17 The average pH and absorbance at 660 nm during two individual fermentations of glucose in the presence of 2.0 mg/L $\text{FeSO}_4 \cdot 7\text{H}_2\text{O}$. The pH dropped sharply with little fluctuation before settling at 5.4 at 72 hours

The sharp drop in pH in the first 10 hours did not correlate with the generation of acids as the acid concentrations decreased during that time, similar to fermentation with 0.5 mg/L additional iron sulfate supplementation. Unlike previous fermentations, the glucose consumption and solvent production continued to 72 hours post-inoculation before stabilizing for the remainder of the 96 hour fermentation as shown in Figure 18. The total organic acids dropped to an average of 1.5 g/L while solvents increased to an average of 10.9g/L.

The maximum concentrations of solvents produced in the fermentation of 31.9 g/L glucose were 7.0 g/L butanol (68% of the total solvents), 3.1 g/L 2-propanol (30% of the total

solvents), 0.1 g/L ethanol (1% of the total solvents) and 0.1 g/L acetone (1% of the total solvents). The solvent production totaled 10.3 g/L in the 96 hour fermentation.

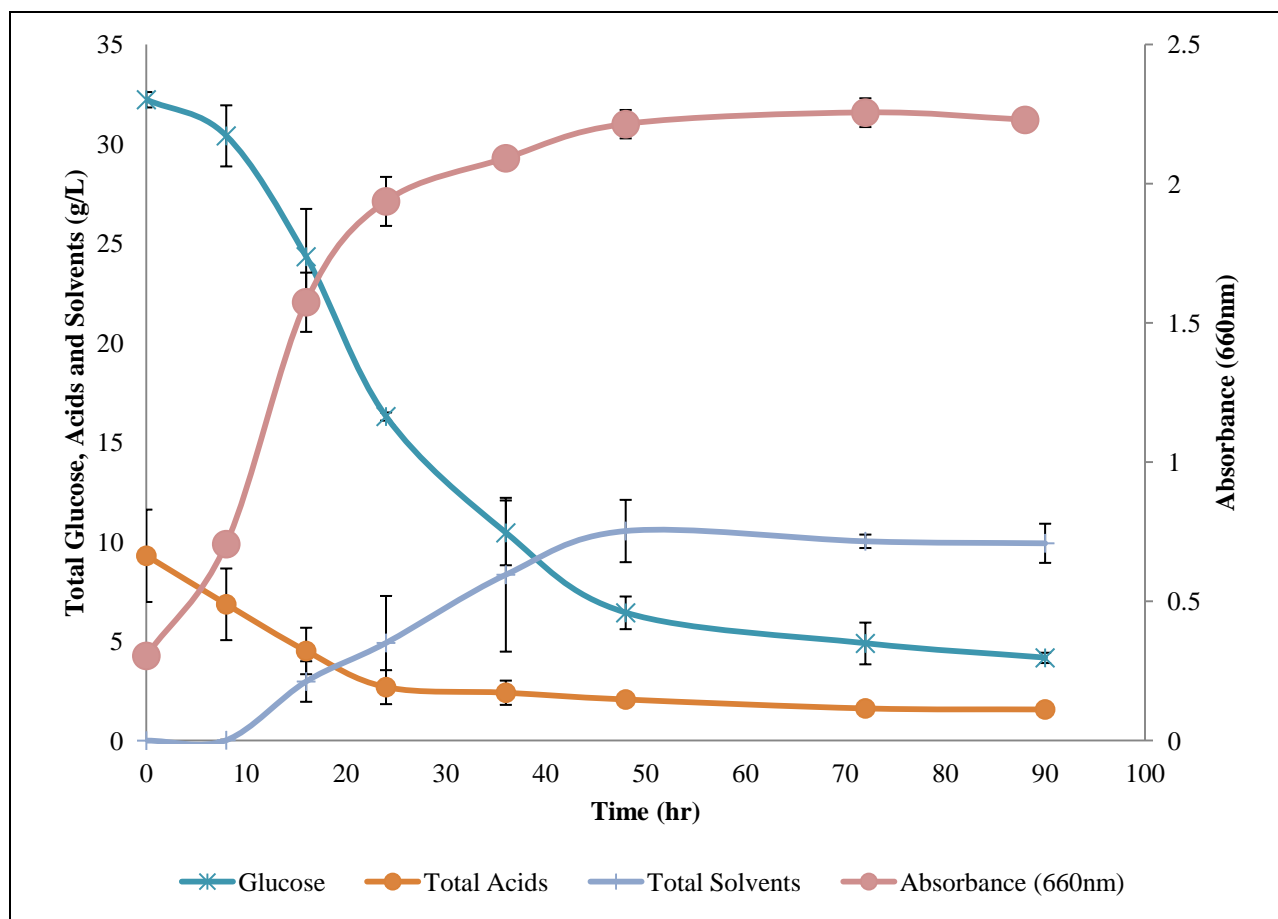

Figure 18 The average total glucose, acids and solvents during two fermentations glucose with 2.0 mg/L $\text{FeSO}_4 \cdot 7\text{H}_2\text{O}$ plus and minus the sample standard deviations. Glucose concentration dropped from 32.2 g/L to 4.2 g/L, total acids dropped from 9.3 g/L to 1.5 g/L and total solvents rose to 11.0 g/L

The maximum concentrations of solvents produced in the fermentation of 32.4 g/L glucose were 7.6 g/L butanol (65% of total solvents), 3.9 g/L 2-propanol (33% of total solvents), 0.1 g/L ethanol (1% of total solvents) and 0.1 g/L acetone (1% of total solvents). The solvent production totaled 11.6 g/L in 48 hours post-inoculation.

The average solvent production over time is shown in Figure 19.

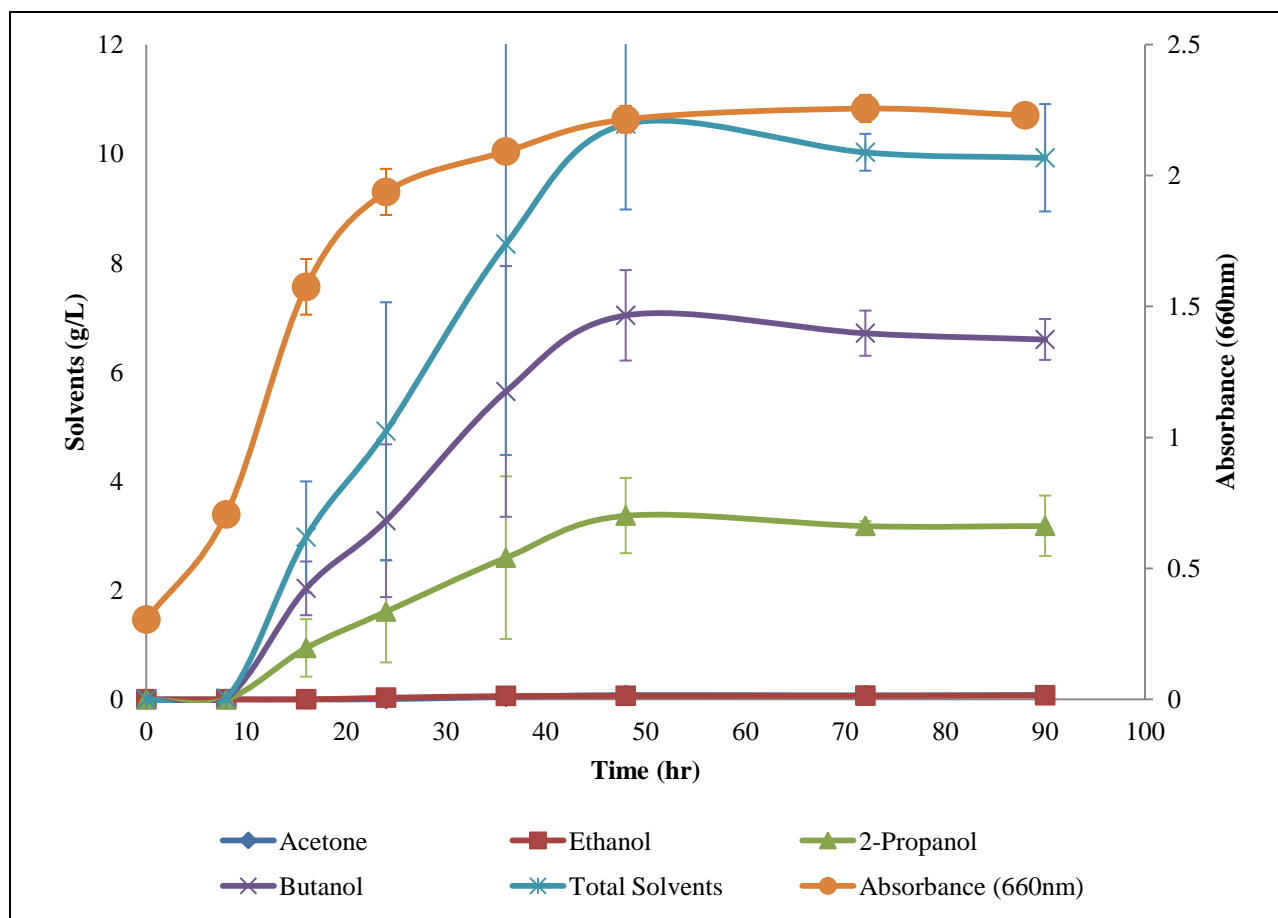

Figure 19 Concentration of solvents generated during two fermentations of glucose in the presence of 2.0 mg/L $\text{FeSO}_4 \cdot 7\text{H}_2\text{O}$. The average total solvents reached 10.9 g/L as 7.0 g/L butanol, 3.4 g/L 2-propanol, 0.1 g/L ethanol and 0.1 g/L acetone were produced

The physiological appearance of the cells followed the same pattern as seen in other fermentations of glucose in the presence of lower concentrations of iron sulfate. As the fermentation of glucose in the presence of an additional 1 mg/L iron sulfate progressed, the cells elongated and multiplied for the first 16 hours before shortening and forming spores by 24 hours. Beyond 24 hours, the spores were released from the cells into the fermentation broth. Microscopic images are shown in Figure 20.

The fermentations of glucose in the presence of 2.0 mg/L $\text{FeSO}_4 \cdot 7\text{H}_2\text{O}$ produced 7.0 g/L and 7.6 g/L butanol. The yield of butanol were 0.24 to 0.25 grams of butanol per gram of sugar utilized in 96 hours. The maximum rate of productivity of butanol was 0.20 g/L/hr.

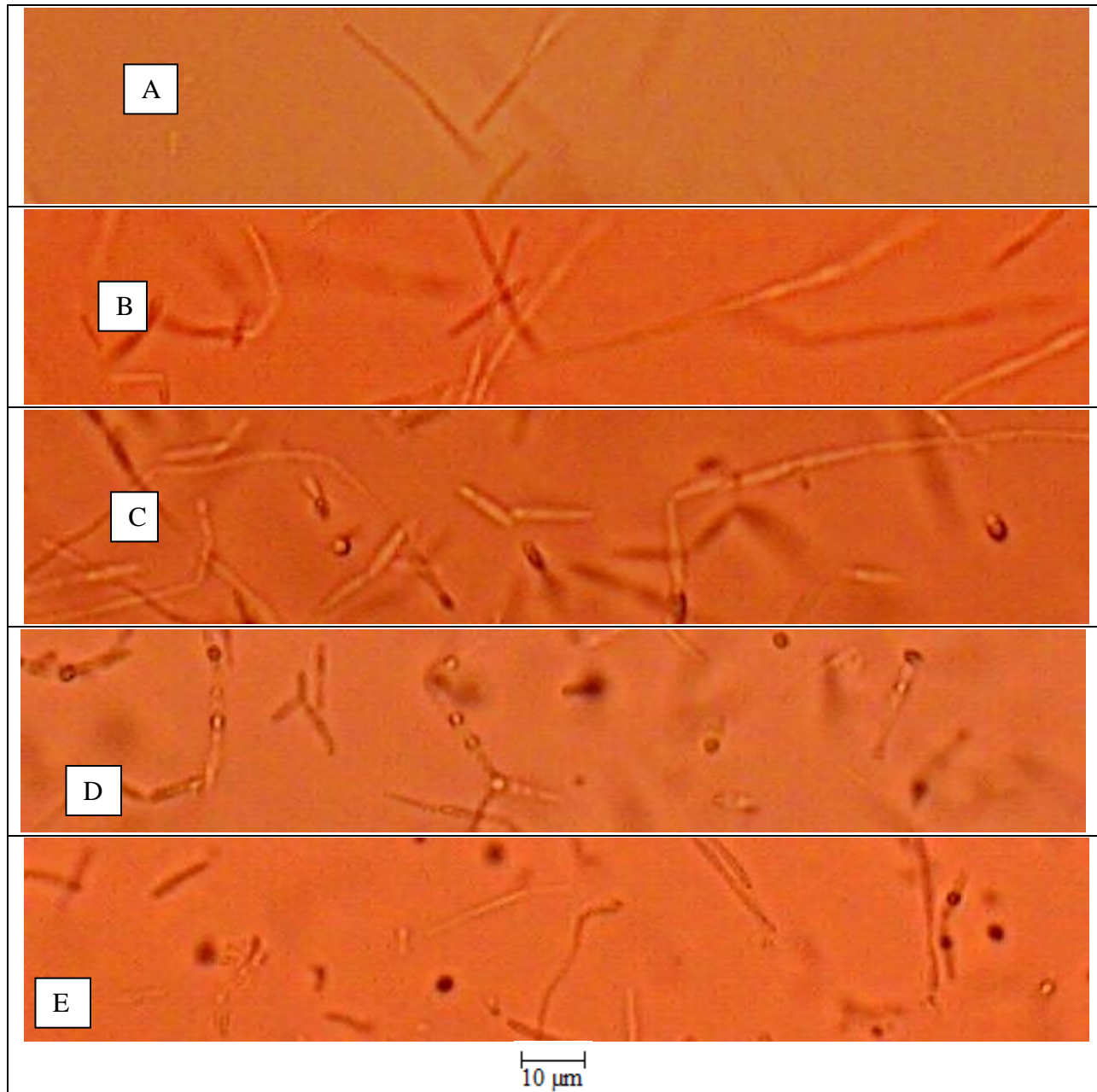

Figure 20 Microscopic images of *C. beijerinckii optonii* culture grown in P2 media containing 31.9 g/L glucose and 2.0 mg/L $\text{FeSO}_4 \cdot 7\text{H}_2\text{O}$ at 8 hours (A), 16 hours (B), 24 hours (C), 36 hours (D), and 48 hours (E). The cells continued to elongate during the first 24 hours post-inoculation and formed spores by 36 hours

Glucose Fermentation with 0.5 mg/L (1.8µM) $\text{FeSO}_4 \cdot 7\text{H}_2\text{O}$. The fermentation of 27.6 g/L glucose in modified P2 medium containing 0.5 mg/L rather than the standard 1.0 mg/L $\text{FeSO}_4 \cdot 7\text{H}_2\text{O}$ had a shorter lag phase than fermentations with higher iron concentration.

As seen in all fermentations, the pH decreased and increased several times over the duration of the fermentation as the acids built up and then converted to solvents. The lag time for the drop in pH was nominal as pH decreased from 6.1 to 5.1 by 10 hours (Figure 21). The pH fluctuated before it settled around 5.4.

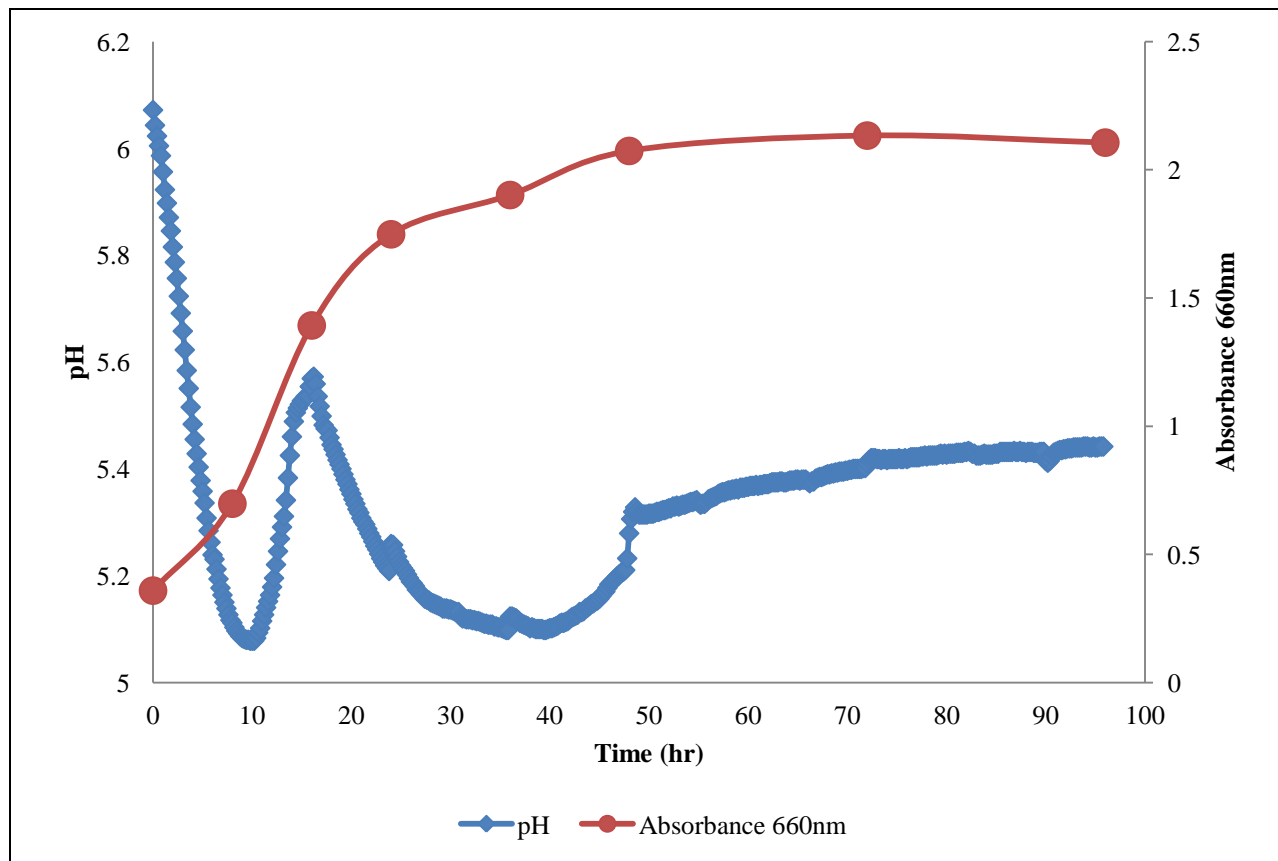

Figure 21 The pH during fermentation of 27.6 g/L glucose with 0.5 mg/L $\text{FeSO}_4 \cdot 7\text{H}_2\text{O}$. The pH dropped sharply from 6.1 to 5.08 and had a large peak around 18 hours before dropping and rising again to 5.44

Acids increased for the first 8 hours from 5.4 g/L to 7.6 g/L and then slowly decreased for the remainder of the fermentation to 1.9 g/L. The majority of glucose was consumed and solvents produced within 48 hours and marginal loss of acids and sugars cause a small gain in total solvents after the first 48 hours. The maximum amount of solvents was achieved at 72 hours as 12.3 g/L total solvents were generated. Sugar, acids and solvents totals are shown in Figure 22.

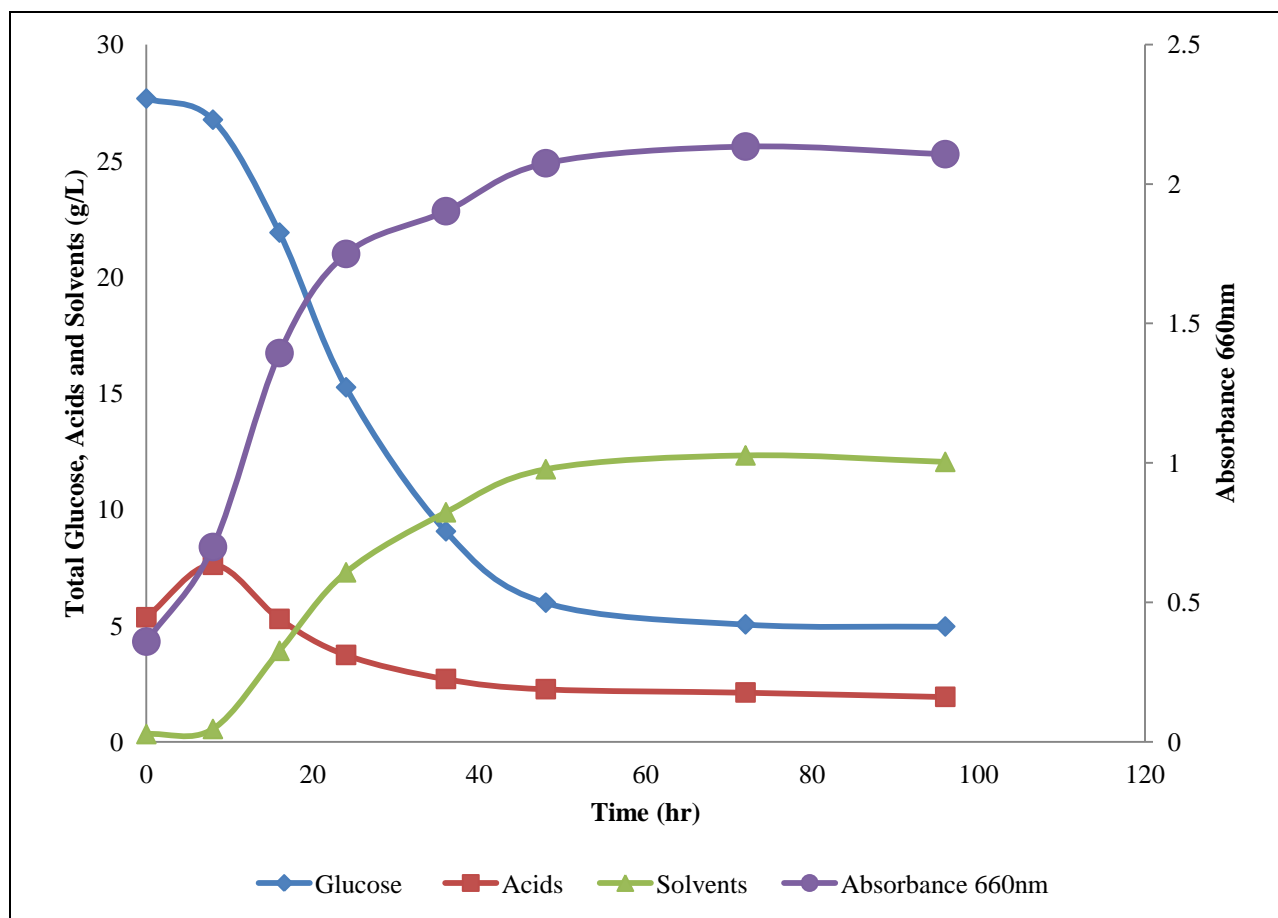

Figure 22 Totals of the glucose, organic acids and total solvents during the fermentation of 27.6 g/L glucose with 0.5 mg/L $\text{FeSO}_4 \cdot 7\text{H}_2\text{O}$

The solvent production totaled 12.3 g/L in the first 72 hours of fermentation. Butanol makes up the majority of the solvent created in the fermentation at 8.0 g/L (65% of total solvents). The fermentation also produced 3.8 g/L 2-propanol (31% of total solvents), 0.2 g/L ethanol (2% of total solvents) and 0.3 g/L acetone (2% of total solvents) as shown in Figure 23.

The bacteria changed physically and morphologically during the course of the fermentation in a similar manner to the fermentations of P2 media containing 1.0 mg/L and 1.5 mg/L $\text{FeSO}_4 \cdot 7\text{H}_2\text{O}$. As seen with the other glucose fermentations, the cells initially started as shortened bacilli for the first 8 hours during the lag phase of fermentation. The cells began to lengthen as the pH dropped and glucose consumption accelerated and then shorten again as the pH began to rise and solvents began to form. By 24 hours, spores formed within the cells. As

growth entered the death phase of fermentation, cells lysed and spores were released into the medium. The death phase in the fermentation with 0.5 mg/L iron sulfate in the medium occurred later than it did in other glucose fermentations as the lysed cells did not appear until 96 hours, though sporulation began within 24 hours. The number of actively growing cells decreased and the number of spores increased as the fermentation progressed beyond 36 hours. Microscopic images are shown in Figure 24.

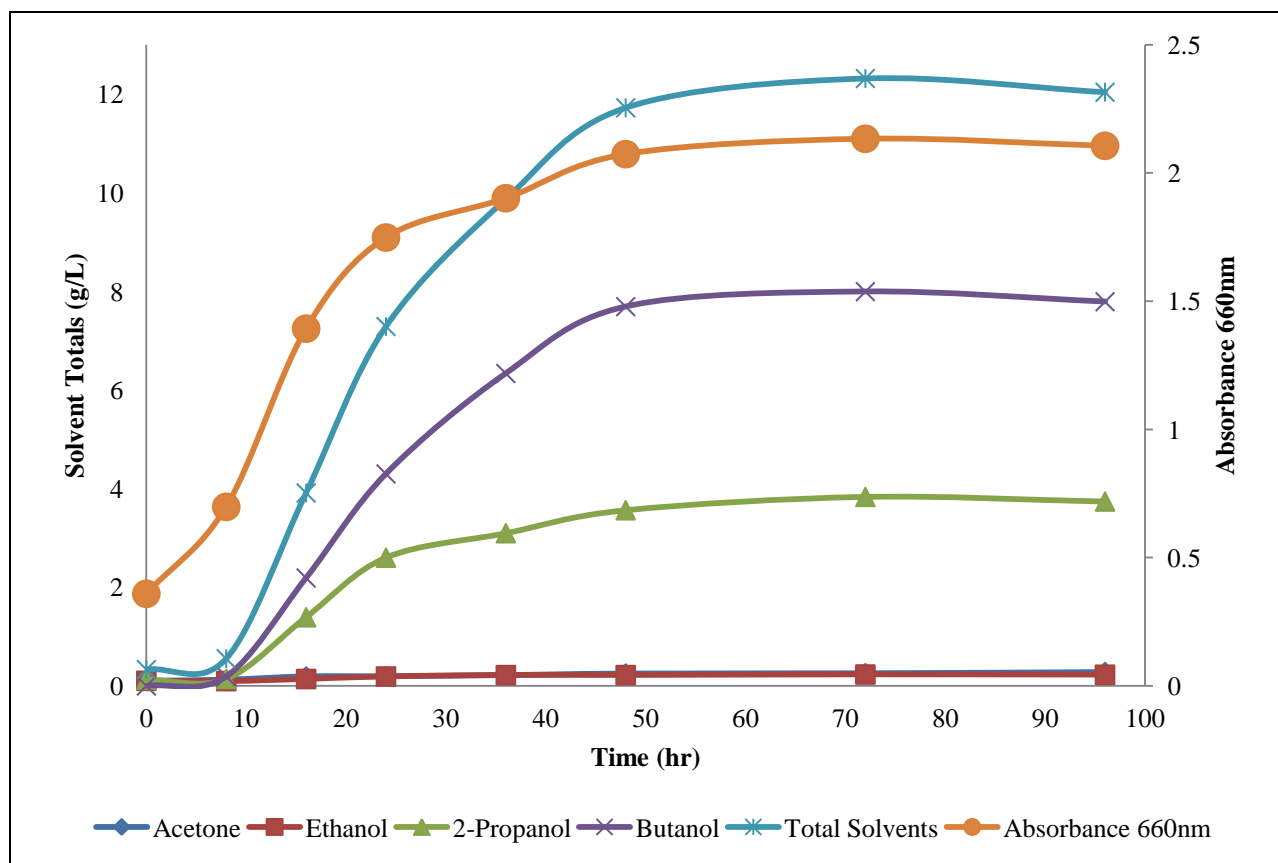

Figure 23 Formation of solvents during the fermentation of 27.6 g/L glucose with 0.5 mg/L $\text{FeSO}_4 \cdot 7\text{H}_2\text{O}$. Total solvents reached 12.32 g/L at 72 hours. The composition of the solvents was 8.00 g/L butanol, 3.83 g/L 2-propanol, 0.23 g/L ethanol and 0.26 g/L acetone

The fermentation of 27.6 g/L glucose in the presence of 0.5 mg/L $\text{FeSO}_4 \cdot 7\text{H}_2\text{O}$ utilized 22.7 g/L glucose to produce 8.0 g/L butanol. The yield of butanol was 0.35 grams of butanol per gram of sugar utilized. The maximum productivity of butanol was 0.18 g/L/hr.

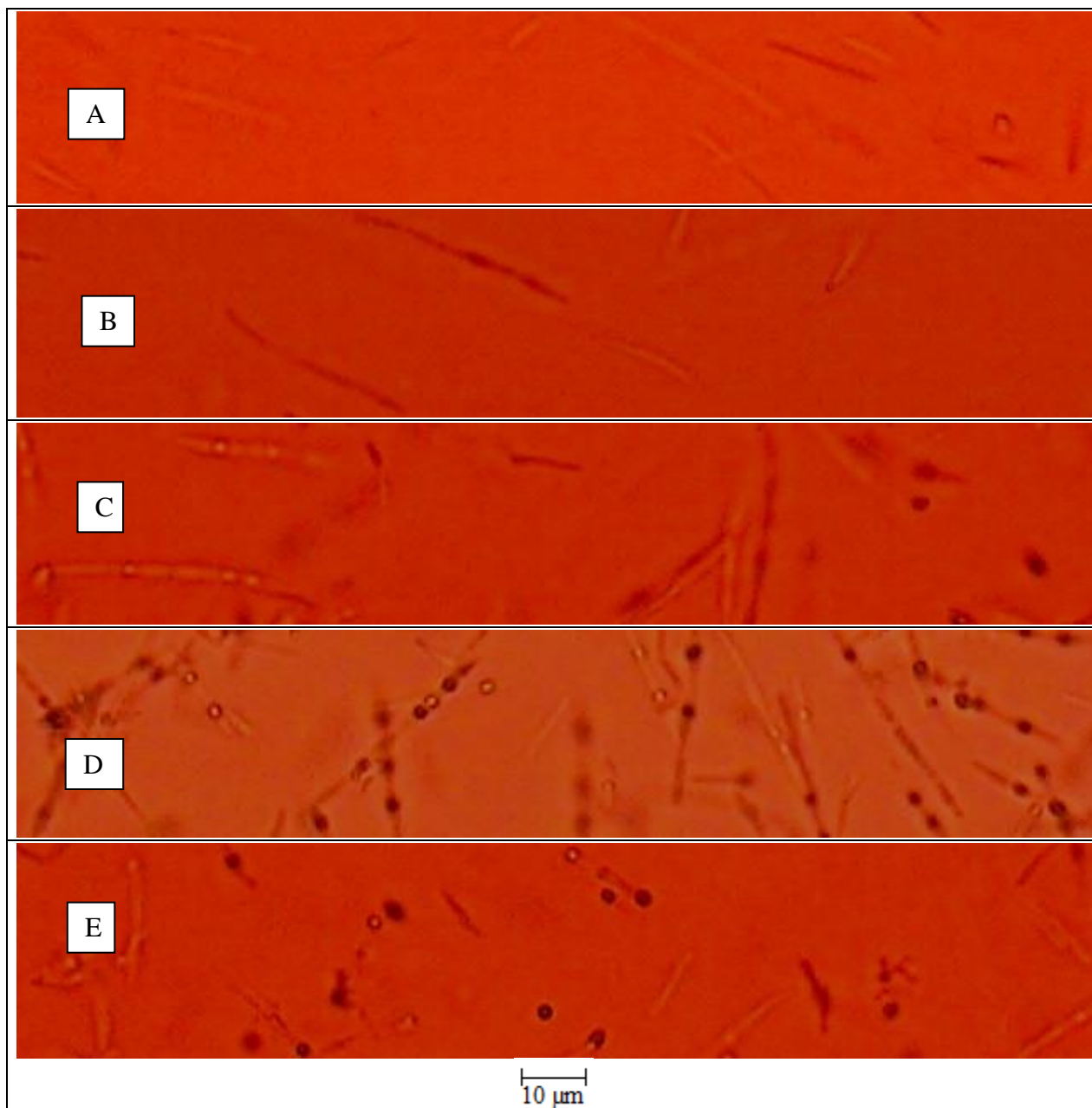

Figure 24 Microscopic images of *C. beijerinckii optonii* cultures grown in 27.6 g/L glucose medium with 0.5 mg/L $\text{FeSO}_4 \cdot 7\text{H}_2\text{O}$ at 8 hours (A), 16 hours (B), 24 hours (C), 36 hours (D) and 48 hours (E). As seen with other glucose fermentations, cells elongated for the first 16 hours, spores formed at 24 hours and spores were released from cells after 48 hours.

Glucose Fermentation with 0.5 mg/L (1.8 μM) $\text{FeSO}_4 \cdot 7\text{H}_2\text{O}$ with Inhibitory pH. The fermentation of 32.1 g/L glucose in P2 medium with 0.5 mg/L $\text{FeSO}_4 \cdot 7\text{H}_2\text{O}$ started in a manner similar to the previous fermentation with 0.5 mg/L $\text{FeSO}_4 \cdot 7\text{H}_2\text{O}$. As seen with the previous fermentation with 0.5 mg/L iron sulfate, the pH dropped at the same rate and rose in a similar

fashion. However, since the initial pH was 5.8, almost 0.3 units lower than the previous fermentation in similar medium, the drop of pH went below 4.9 on the initial drop. The subsequent drop brought the pH below 4.8 at 32 hours post-inoculation and the culture was unable to fully recover. The pH and absorbance of both fermentations of glucose in the presence of 0.5 mg/L $\text{FeSO}_4 \cdot 7\text{H}_2\text{O}$ is shown in Figure 25.

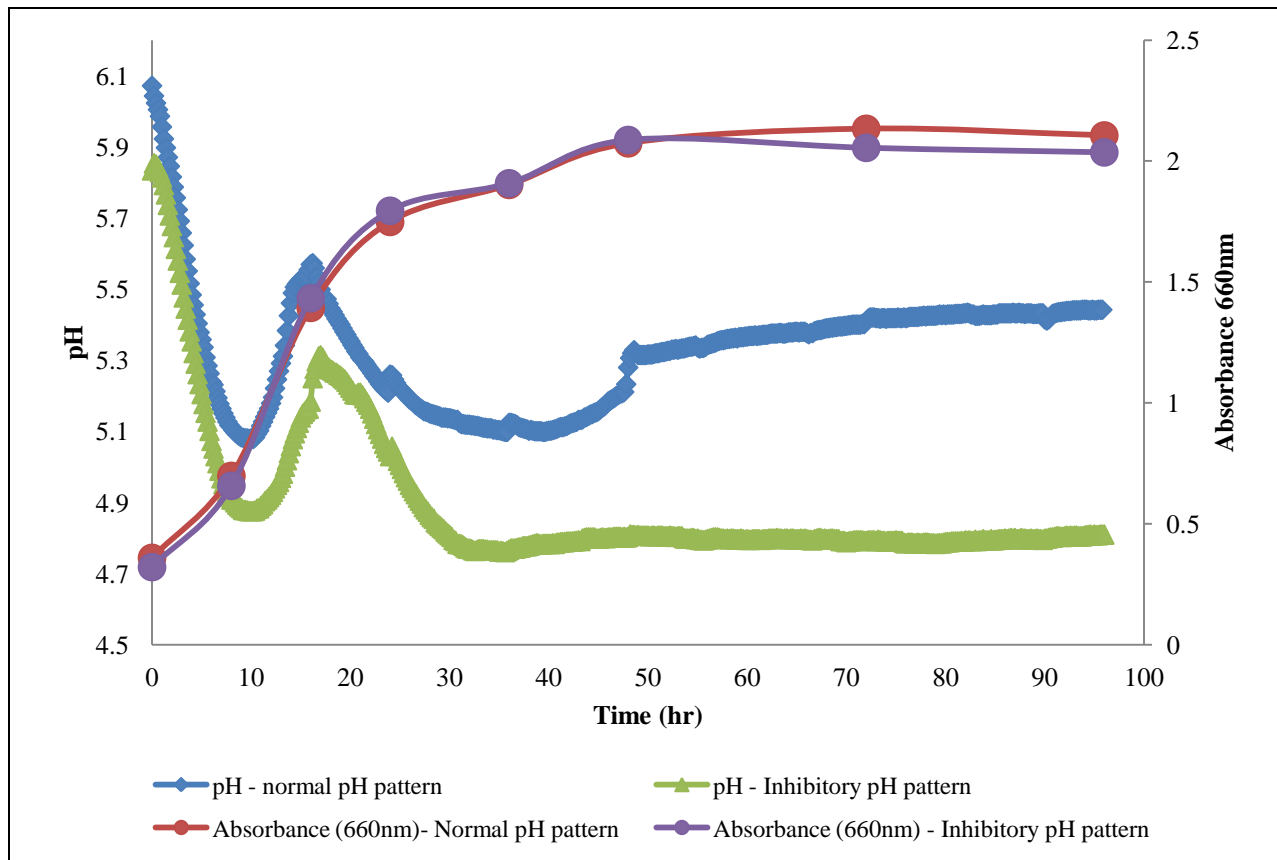

Figure 25 The pH and absorbance at 660nm during fermentation of 32.1 g/L glucose with 0.5 mg/L $\text{FeSO}_4 \cdot 7\text{H}_2\text{O}$ with inhibitory pH compared to the pH and absorbance at 660nm in a fermentation of glucose with 0.5 mg/L $\text{FeSO}_4 \cdot 7\text{H}_2\text{O}$ with normal pH pattern. The pH followed the same pattern as the previous fermentation in similar medium until the pH dropped to 4.8 and was unable to recover and rise in a similar manner

Unlike most fermentations using glucose as a feedstock, the sharp drop in pH in the first 10 hours post-inoculation correlated with the generation of acids as the acid concentrations increased during that time, similar to the other fermentation with 0.5 mg/L iron sulfate in P2 medium. The majority of glucose consumption and solvent production was completed by 48

hours post-inoculation, which was the time at which the pH stabilized. Figure 26 shows the total glucose, acids and solvents during the fermentation.

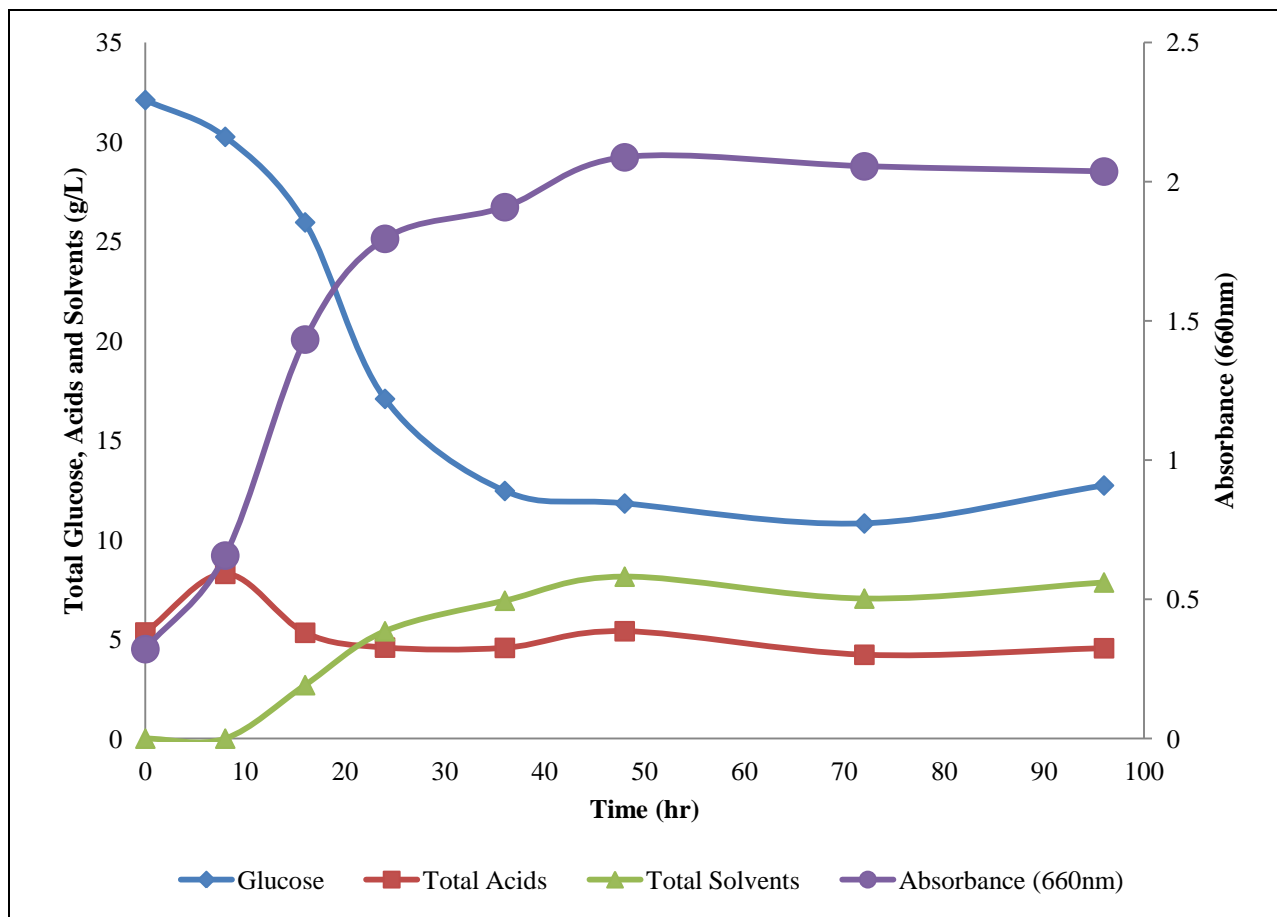

Figure 26 The total glucose, acids and solvents during the fermentation of 32.1 g/L glucose with 0.5 mg/L $\text{FeSO}_4 \cdot 7\text{H}_2\text{O}$. Glucose concentration dropped from 32.1 g/L to 10.8 g/L. Total acids rose from 5.3 g/L to 8.3 g/L in the first 8 hours post-inoculation and then dropped to 4.2 g/L by 72 hours post-inoculation. Total solvents rose to 8.1 g/L at 48 hours post-inoculation

The maximum concentrations of solvents produced were 5.6 g/L butanol (70% of total solvents), 2.4 g/L 2-propanol (30% of total solvents), 0.1 g/L ethanol (1% of total solvents) and 0.02 g/L acetone (0% of total solvents) as shown in Figure 27. The solvent production totaled 8.1 g/L in the first 48 hours post-inoculation.

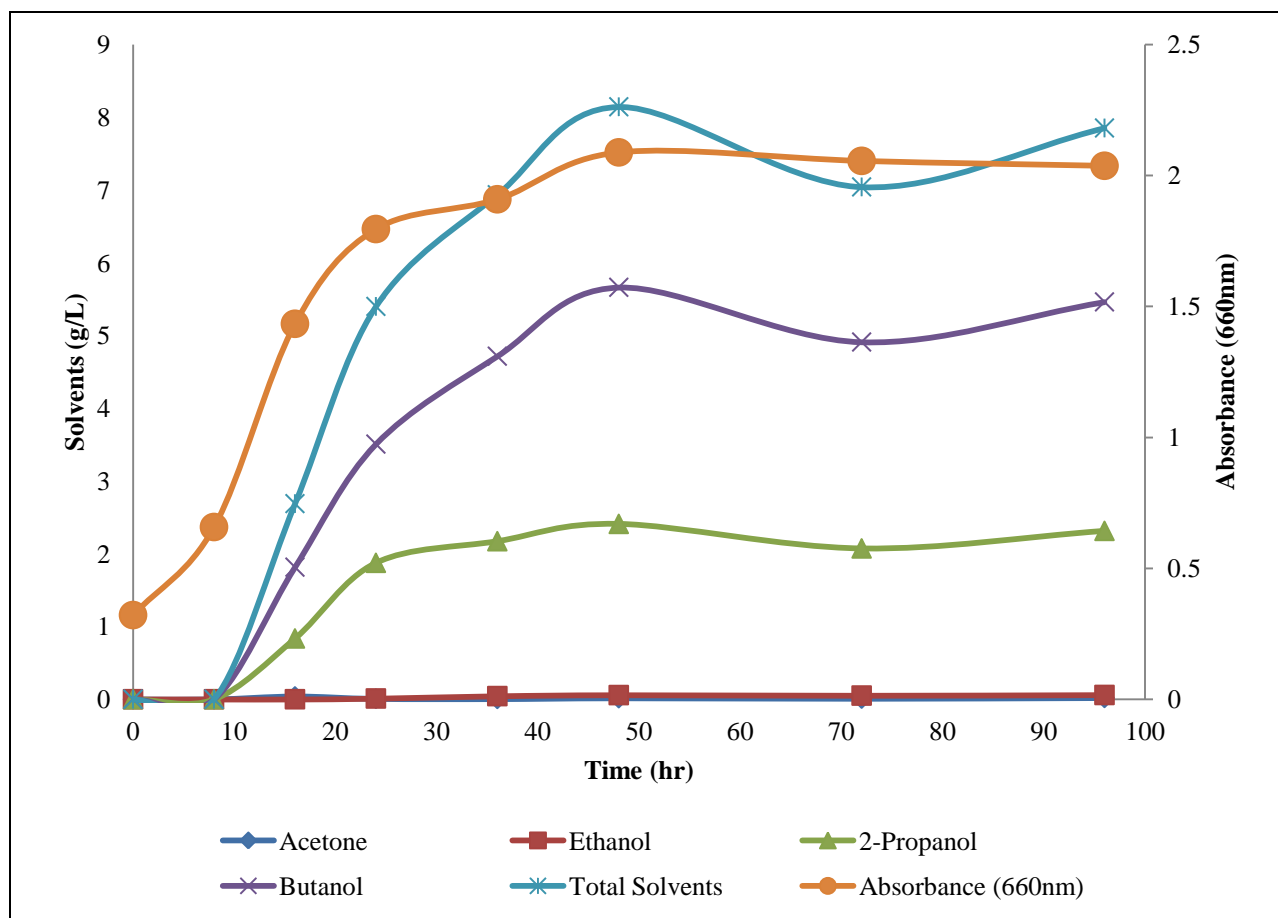

Figure 27 Concentration of solvents generated during the fermentation of 32.1 g/L glucose with 0.5 mg/L $\text{FeSO}_4 \cdot 7\text{H}_2\text{O}$. The total solvents reached 8.1 g/L as 5.6 g/L butanol, 2.4 g/L 2-propanol, 0.1 g/L ethanol and 0.02 g/L acetone were produced 48 hours post-inoculation

As the fermentation of glucose in the presence of 0.5 mg/L iron sulfate progressed, the cells elongated and multiplied. Unlike most other fermentations with glucose as a feedstock, the cells remained elongated through 36 hours post-inoculation before lysis occurred by 48 hours.

Microscopic images are shown in Figure 28.

The fermentation produced 5.7 g/L butanol. The yield of butanol was 0.27 grams of butanol per gram of sugar utilized. The maximum rate of productivity of butanol was 0.15 g/L/hr.

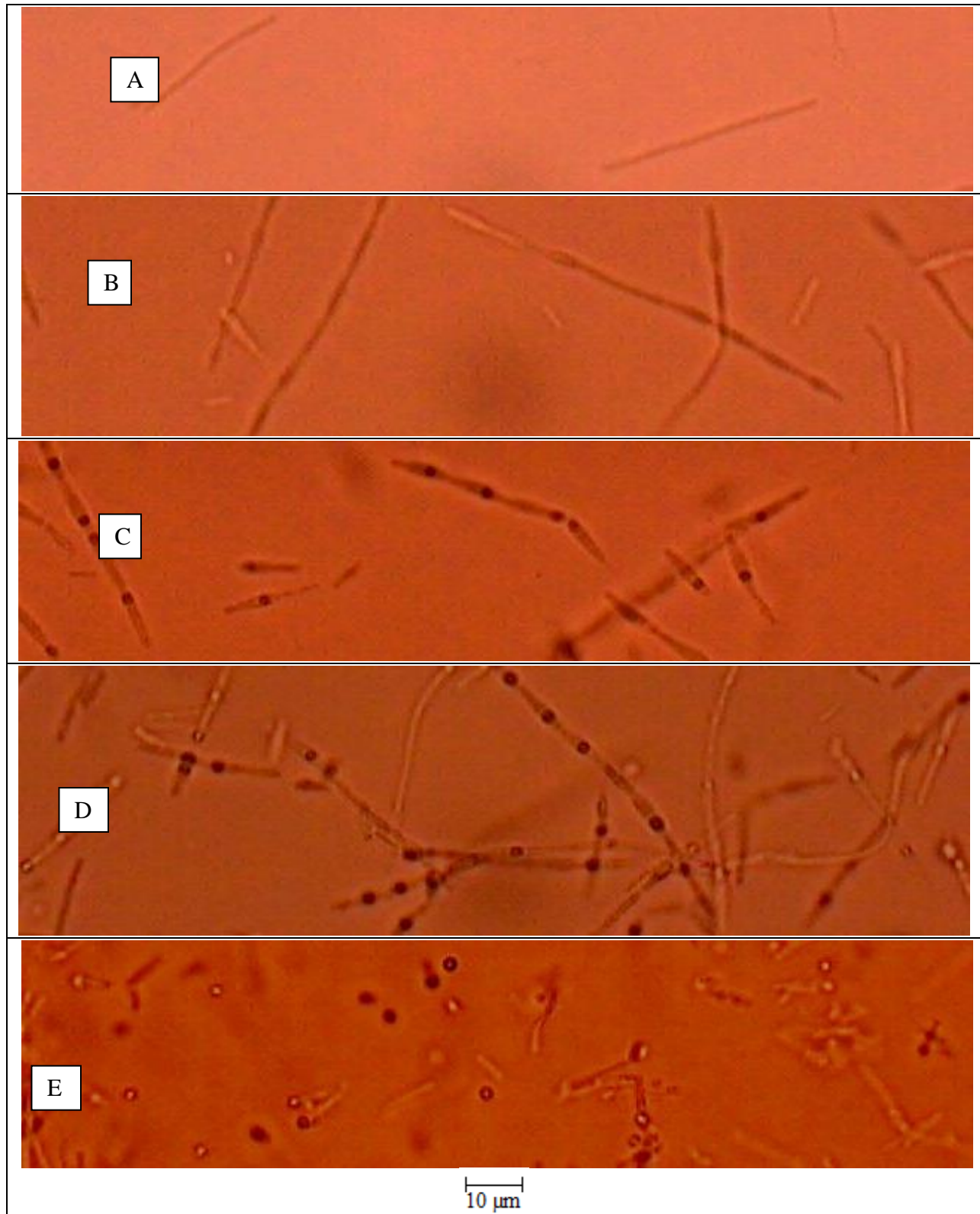

Figure 28 Microscopic images of *C. beijerinckii optonii* culture grown in 32.1 g/L glucose with 0.5 mg/L $\text{FeSO}_4 \cdot 7\text{H}_2\text{O}$ at 8 hours (A), 16 hours (B), 24 hours (C), 36 hours (D) and 48 hours (E). The cells continued to elongate during the fermentation and formed spores by 24 hours

Glucose Fermentation with 2.0 mg/L (7.2 μ M) FeSO₄·7H₂O with Inhibitory pH. The fermentation of 30.1 g/L glucose in P2 medium plus an additional 1.0 mg/L FeSO₄·7H₂O was similar to other glucose fermentations. As seen with the fermentation with 0.5 mg/L additional iron sulfate, the pH fluctuation was less pronounced than the fermentation without additional iron. The pH rapidly dropped from 5.7 to 4.8 before stabilizing and settling at 4.6 (Figure 29).

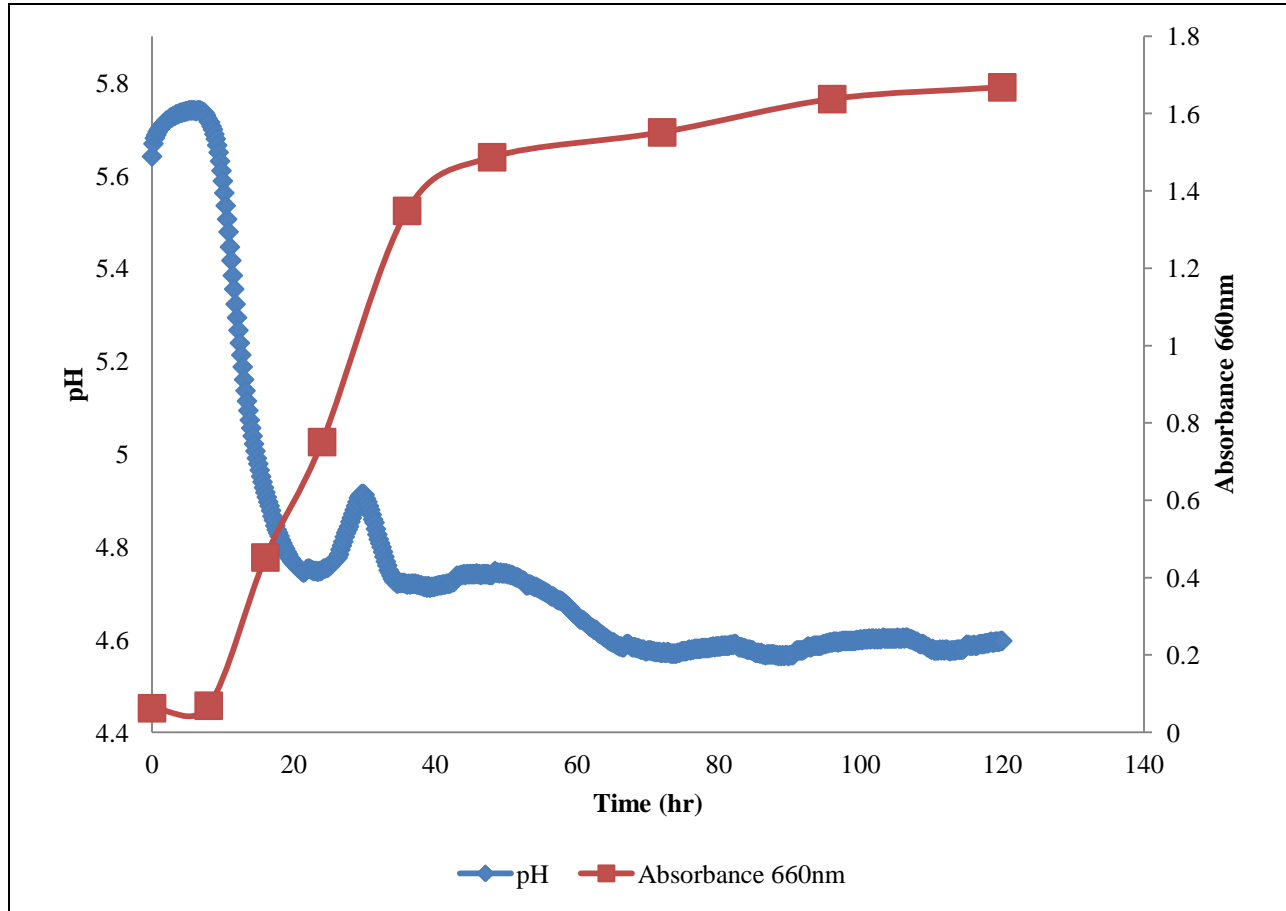

Figure 29 The pH during fermentation of 30.1 g/L glucose with 2.0 mg/L FeSO₄·7H₂O. The pH dropped sharply with little fluctuation before settling at 4.6 at 72 hours

The sharp drop in pH from 8 to 24 hours also did not correlate with the generation of acids as the acid concentrations decreased during that time, similar to fermentation with 0.5 mg/L iron sulfate supplementation with low terminal pH. Unlike previous fermentations, the glucose consumption and solvent production continued to 72 hours post-inoculation before stabilizing for the remainder of the 96 hour fermentation as shown in Figure 30.

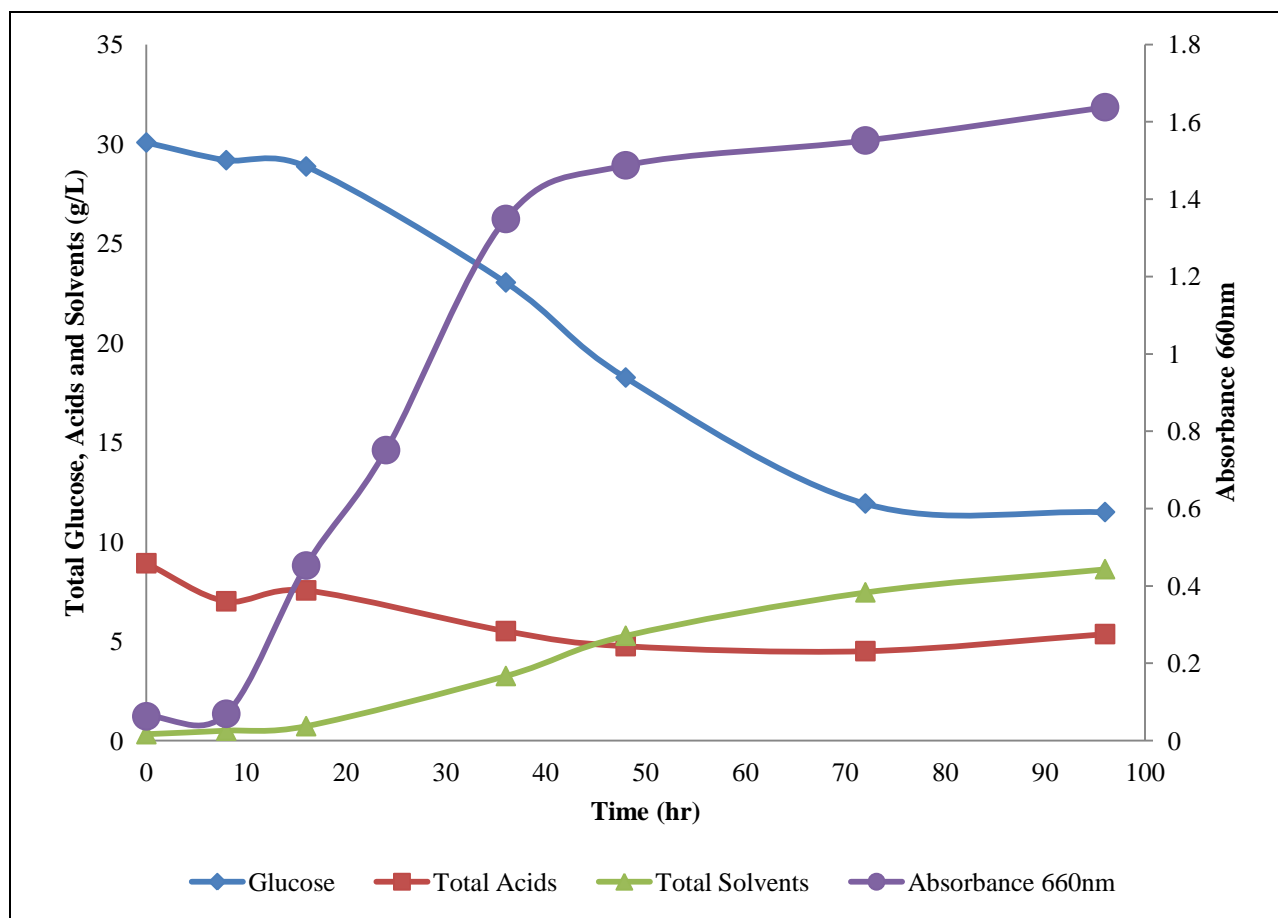

Figure 30 The total glucose, acids and solvents during the fermentation of 30.1 g/L glucose with 2.0 mg/L $\text{FeSO}_4 \cdot 7\text{H}_2\text{O}$. Glucose concentration dropped from 30.1 g/L to 11.5 g/L. Total acids dropped from 7.3 g/L to 2.6 g/L at 72 hours and rose to 3.1 g/L at 96 hours. Total solvents rose to 8.6 g/L at 96 hours

The maximum concentrations of solvents produced were 5.9 g/L butanol (69% of total solvents), 2.1 g/L 2-propanol (25% of total solvents), 0.3 g/L ethanol (3% of total solvents) and 0.3 g/L acetone (3% of total solvents) as shown in Figure 31. The solvent production totaled 8.6 g/L in the 96 hour fermentation.

As the fermentation of glucose in the presence of an additional 1 mg/L iron sulfate progressed, the cells elongated and multiplied. Unlike the other fermentations, these cells did not form spores. Microscopic images are shown in Figure 32.

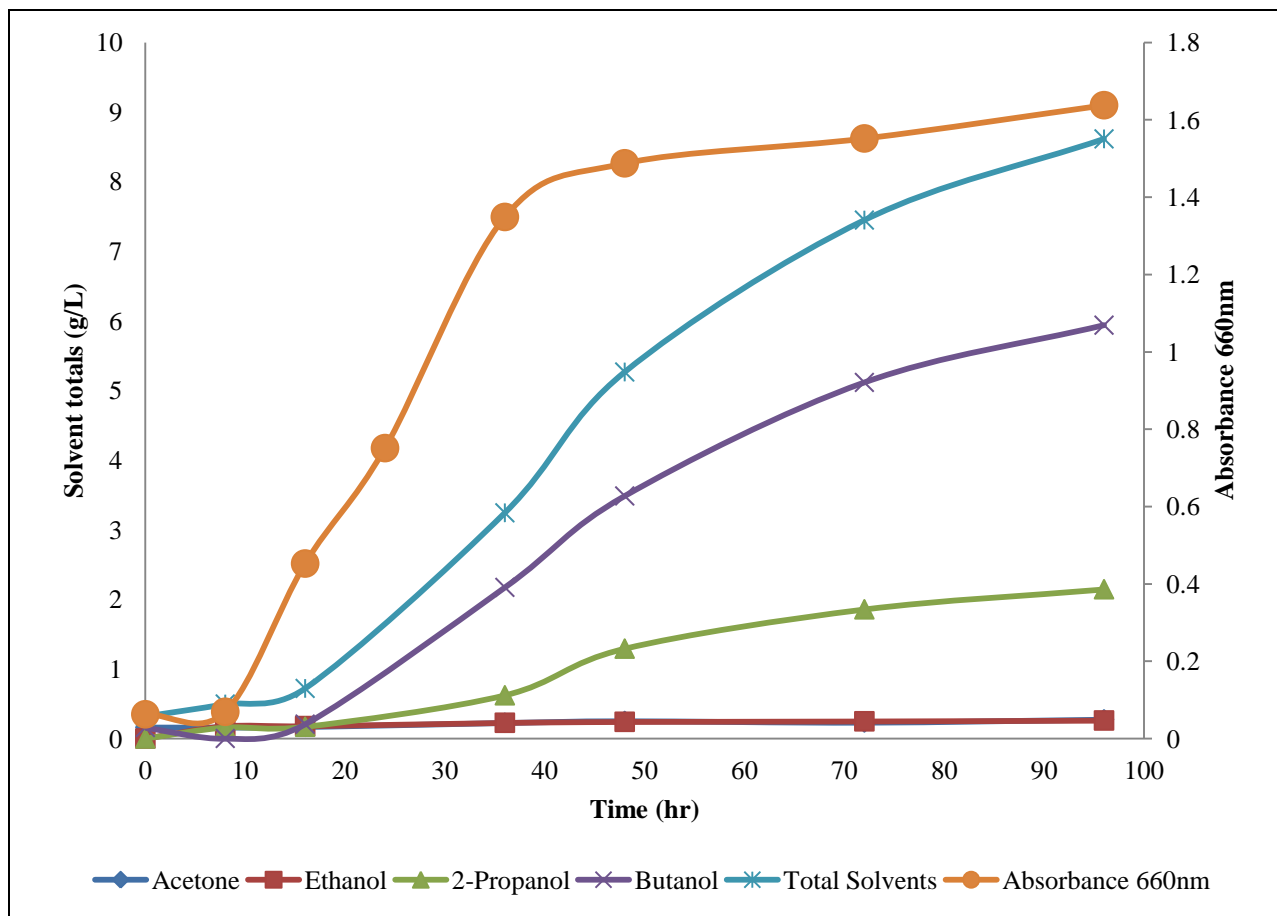

Figure 31 Concentration of solvents generated during the fermentation of 30.1 g/L glucose with 2.0 mg/L $\text{FeSO}_4 \cdot 7\text{H}_2\text{O}$. The total solvents reached 8.6 g/L as 5.9 g/L butanol, 2.1 g/L 2-propanol, 0.3 g/L ethanol and 0.3 g/L acetone were produced

The fermentation produced 5.9 g/L butanol. The yield of butanol was 0.30 grams of butanol per gram of sugar utilized in 96 hours. The maximum rate of productivity of butanol occurred at 48 hours of fermentation with a butanol productivity of 0.07 g/L/hr.

Summary of Iron Supplementation

The iron content of the fermentation media was not shown to significantly affect the solventogenic output of this organism. Table 9 shows the butanol production, total solvent production, butanol productivity, butanol yield, minimum pH and terminal pH values for fermentations with different concentration of $\text{FeSO}_4 \cdot 7\text{H}_2\text{O}$ in P2 media as well as the two instances of low terminal pH.

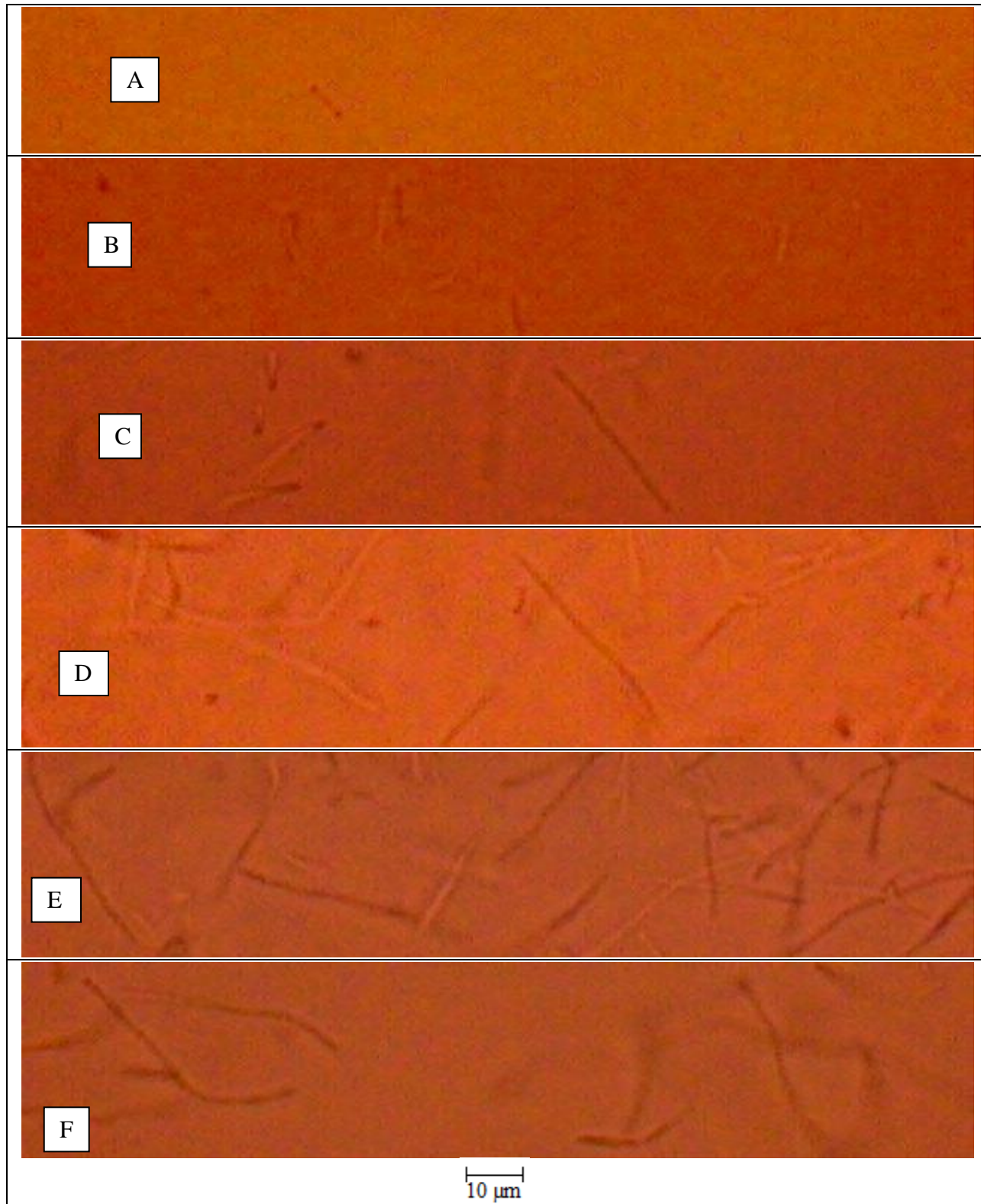

Figure 32 Microscopic images of *C. beijerinckii optonii* culture grown in 30.1 g/L glucose with 2.0 mg/L $\text{FeSO}_4 \cdot 7\text{H}_2\text{O}$ at 8 hours (A), 16 hours (B), 24 hours (C), 36 hours (D), 48 hours (E) and 72 hours (F). The cells continued to elongate during the duration of the fermentation and never formed spores

Table 9 Summary of the Effects of Iron on Fermentation

Concentration of FeSO ₄ ·7H ₂ O (μM)	1.8	1.8 Low pH	3.6	5.4	^a 7.2	7.2 Low pH	^b Upper 95% CI	^b Lower 95% CI
Glucose Consumed (g/L)	22.7	21.3	21.5	20.5	27.4 +/- 0.6	18.6	25.3	20.2
Final Concentration of Butanol (g/L)	8.0	5.7	7.0	6.3	7.3 +/- 0.3	5.9	7.4	6.1
Final Concentration of Total Solvents (g/L)	12.3	8.1	11.5	10.3	11.0 +/- 0.7	8.6	11.6	9.2
Butanol Productivity (g/L/hr)	0.18	0.15	0.16	0.15	0.17 +/- 0.03	0.07	0.18	0.12
Butanol Yield from Glucose (g/g)	0.35	0.27	0.33	0.30	0.25 +/- 0.01	0.30	0.32	0.26
Minimum pH	5.08	4.76	4.94	4.86	4.90 +/- 0.01	4.57	4.74	4.98
Terminal pH	5.44	4.81	5.10	4.89	5.40 +/- 0.05	4.60	4.84	5.34
Rise in pH	0.36	0.05	0.16	0.03	0.49 +/- 0.05	0.03	0.40	0.07

^a mean +/- standard deviation

^b Confidence interval determined by Pooled T test

There was very little correlation between iron content and butanol output. The greatest impact on butanol production is found when the pH drops below 4.80 as butanol and total solvent production were low. The initial pH of fermentation does not have a large impact on the occurrence of acid crash. Figure 33 shows the pH curves of all fermentations using glucose and P2 media starting from the initial drop in pH.

Though the low pH found in two of the fermentations lowered the amount of butanol produced by *C. beijerinckii optonii*, the production of butanol and solvents was not totally inhibited. The solvent production was lowered as the pH was below the optimum range for the solventogenic enzymes to function at a high capacity but solvents were still produced. The percentage of

solvents produced changed as production of acetone and 2-propanol were affected to a greater degree than butanol and ethanol. Table 10 shows the average percentages of solvents formed in fermentations exhibiting low pH and those in which the pH followed normal patterns.

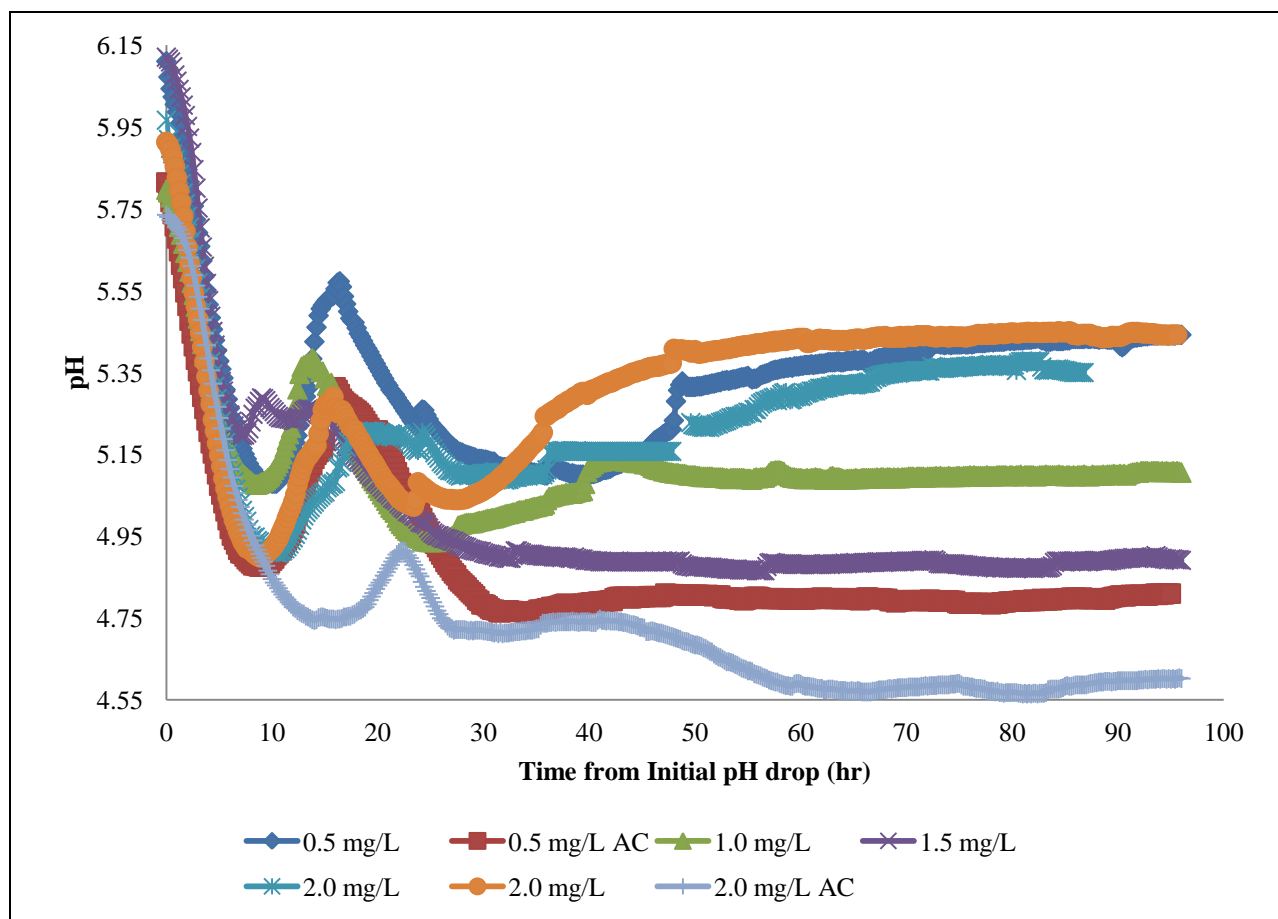

Figure 33 The pH curves of each fermentation using glucose in P2 media. The two fermentations that reached pH below 4.80 and the terminal pH was unable to rise.

Table 10 Percentages of Solvents Formed in Fermentations of Glucose in P2 Media Exhibiting Low Terminal pH and Normal pH Pattern

	Fermentations with normal pH pattern	pH below 4.80	Probability (Paired t test)
Total Solvent Concentration	11.2 (+/- 0.9) g/L	8.4 (+/- 0.3) g/L	P < 0.001
Butanol Concentration	7.2 (+/- 0.7) g/L	5.8 (+/- 0.2) g/L	0.001 < P < 0.01
% Butanol	64.1 (+/- 3.2) %	69.2 (+/- 0.4) %	0.01 < P < 0.02
% 2-Propanol	32.7 (+/- 2.0) %	27.2 (+/- 3.3) %	0.05 < P < 0.1
% Ethanol	1.5 (+/- 1.0) %	1.9 (+/- 1.6) %	P > 0.5
% Acetone	1.7 (+/- 0.9) %	1.7 (+/- 2.1) %	P > 0.5

While the total concentrations of butanol and total solvents and percentage of 2-propanol in the total solvents were significantly lower, the percentage of butanol in the total solvents was higher in the fermentations in which the pH dropped below 4.80.

Glucose Fermentation with Soy Oil as a Coextractant

A 96 hours of fermentation of glucose in P2 medium with the addition of 20% soy oil to the medium produced 6.3 g/L butanol in the aqueous phase and 4.6 g/L butanol in the oil phase. The total solvents produced in both the aqueous phase and the oil phase were 13.9 g/L. The fermentation continued to produce butanol until 144 hours post-inoculation where the final butanol concentration was 8.0 g/L in the aqueous phase and 4.9 g/L in the oil phase. Results from the fermentation are summarized in Table 11.

Table 11 Summarized Results from the Fermentation of 58.2 g/L Glucose with 20% Soy Oil

Sample	Concentration (g/L)		
	0 Hours	96 Hours	144 Hours
Glucose	58.2	23.6	21.2
Butanol (Aqueous)	0	6.2747	8.0163
Butanol (Oil)	0	4.61503	4.91673
Total Solvents (Aqueous)	0	9.03747	11.61043
Total Solvents (Oil)	0	4.85952	5.19507
	Total Weight (g)		
Glucose	87.31	35.46	31.84
Butanol (Aqueous)	0	9.41205	12.02445
Butanol (Oil)	0	1.536805	1.637271
Butanol (Combined)	0	10.94885	13.66172
Total Solvents (Aqueous)	0	13.55621	17.41565
Solvents (Oil)	0	1.61822	1.729958
Solvents (Combined)	0	15.17443	19.1456
Butanol % Increase	N/A	16.32806	13.6161828
Solvents % Increase	N/A	11.93712	9.93335768

The addition of soy oil (333 mL) to 1.5L glucose medium increased the production of butanol by 1.64g (14%) and total solvents by 1.73g (10%). The glucose consumed during the

course of the fermentation was 55.5g giving a yield of butanol from glucose of 0.25 g/g. The glucose, butanol and total solvents during the fermentation are shown in Figure 34.

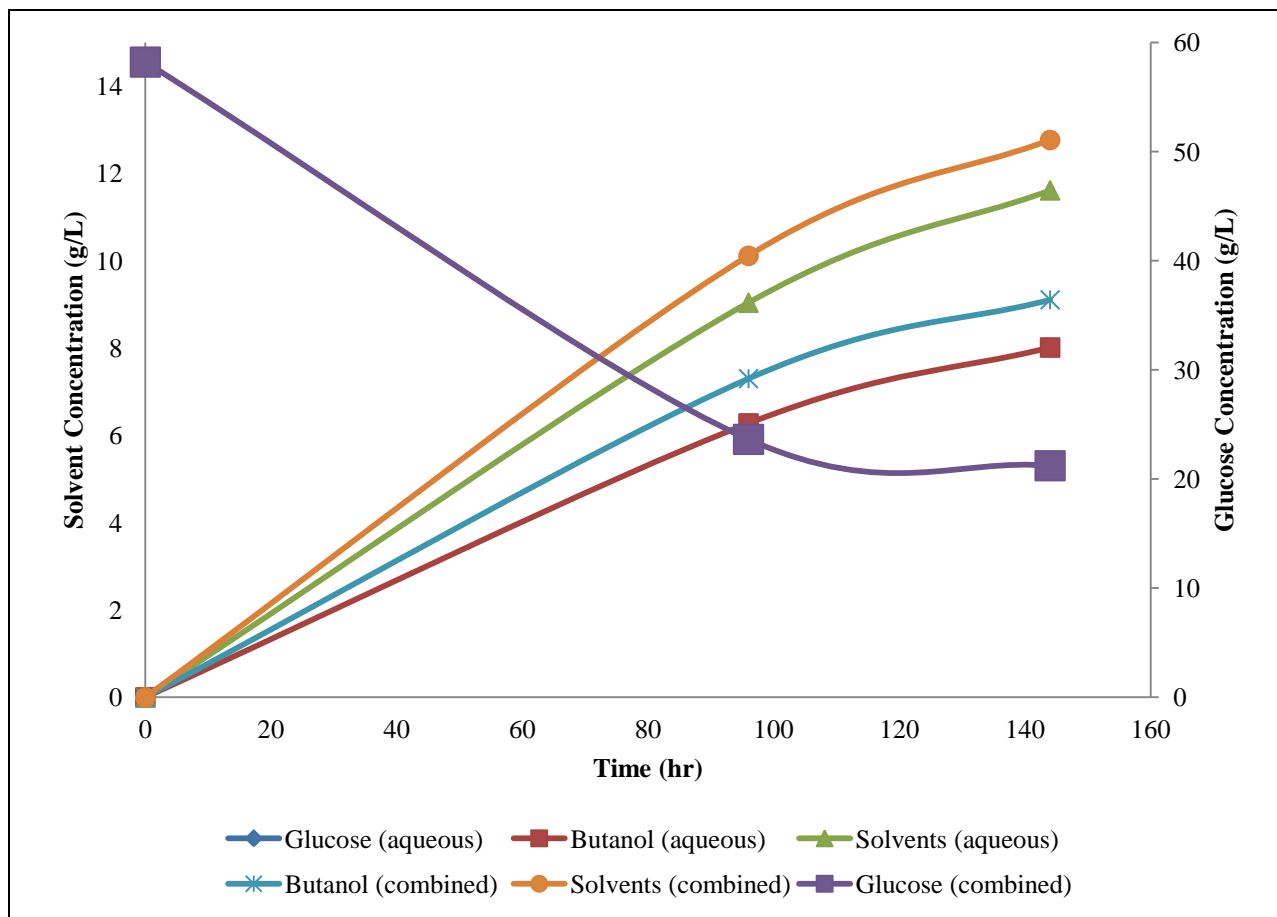

Figure 34 Total mass of glucose, butanol and total solvents during a fermentation of 58.2 g/L glucose with *C. beijerinckii optonii* with 20% oil added for coextraction. Total glucose was decreased from 87.3 g to 31.8 g the 144 hour fermentation as 13.7 g butanol and 19.2 g total solvents were formed

The butanol concentration increased from 8.0 g/L to 9.1 g/L, a 13.6% increase in butanol with the addition of soy oil as a coextractant.

Sugarcane Juice Fermentation

The fermentation of sugarcane juice medium containing glucose (2.5 g/L), fructose (2.3 g/L) and sucrose (49.5 g/L) had a lag time of 5 hours before the pH began to drop. The pH curve was more complex in comparison to fermentations where glucose was the only carbon source. Unlike with the fermentations of only glucose, the pH never stabilized but continued to drop

between 50 hours and 144 hours when the fermentation was stopped. The pH curve is shown in Figure 35.

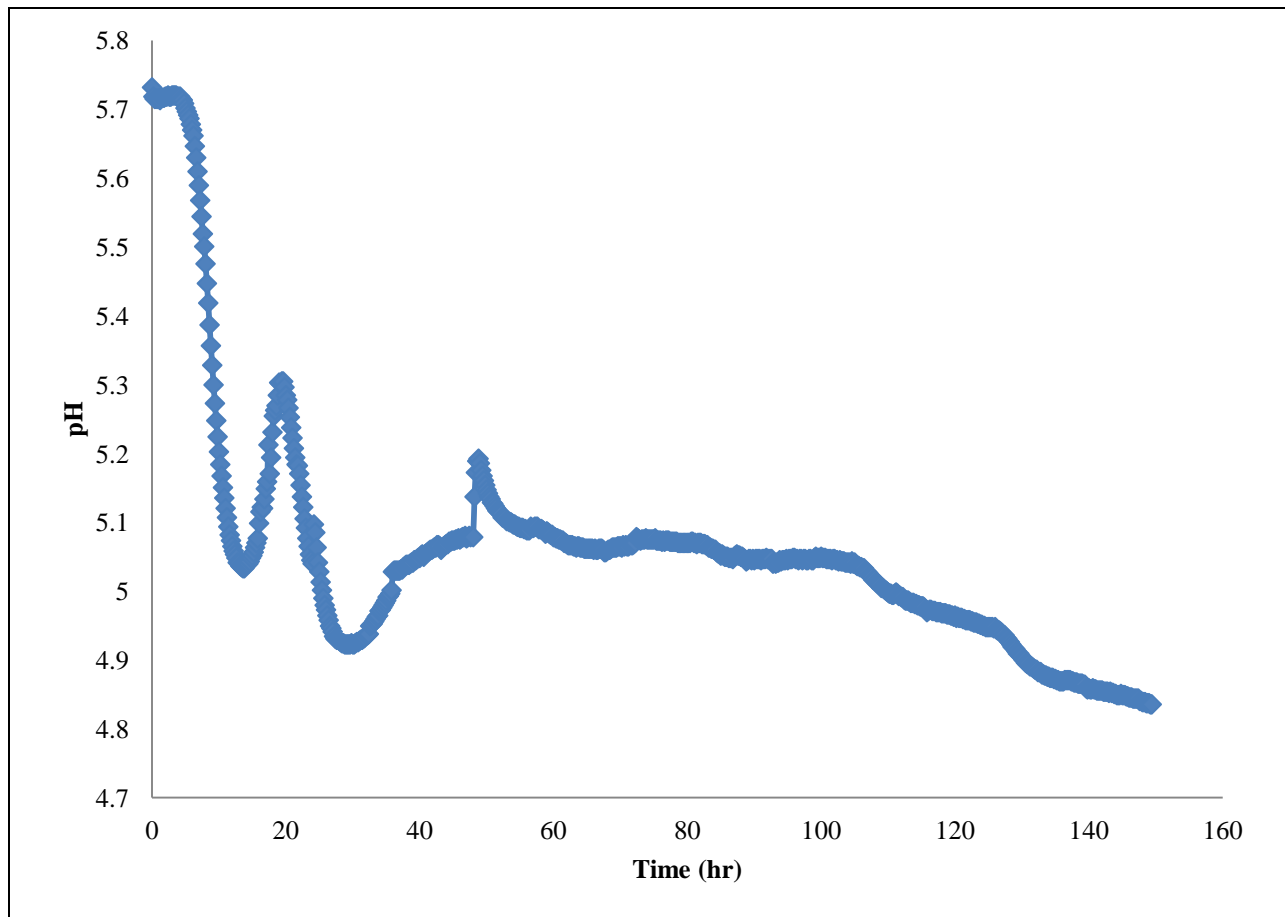

Figure 35 pH curve during the fermentation of sugarcane juice medium containing 54.3 g/L total sugars by *C. beijerinckii optonii*. The pH has several sharp peaks and valleys and starts a steady drop from 5.04 to 4.8 from 100 to 144 hours

The *C. beijerinckii optonii* cells followed the same pattern of growth during the fermentation of sugarcane juice medium as they did with fermentation of glucose medium with 1 mg/L total iron sulfate as shown in Figure 36. The cells multiplied rapidly and elongated for the first 12 hours and shortened while forming spores by 24 hours. Some spores floated freely in solution by 36 hours and the number of free spores increased while the number of actively growing cells decreased as the fermentation progressed beyond 36 hours.

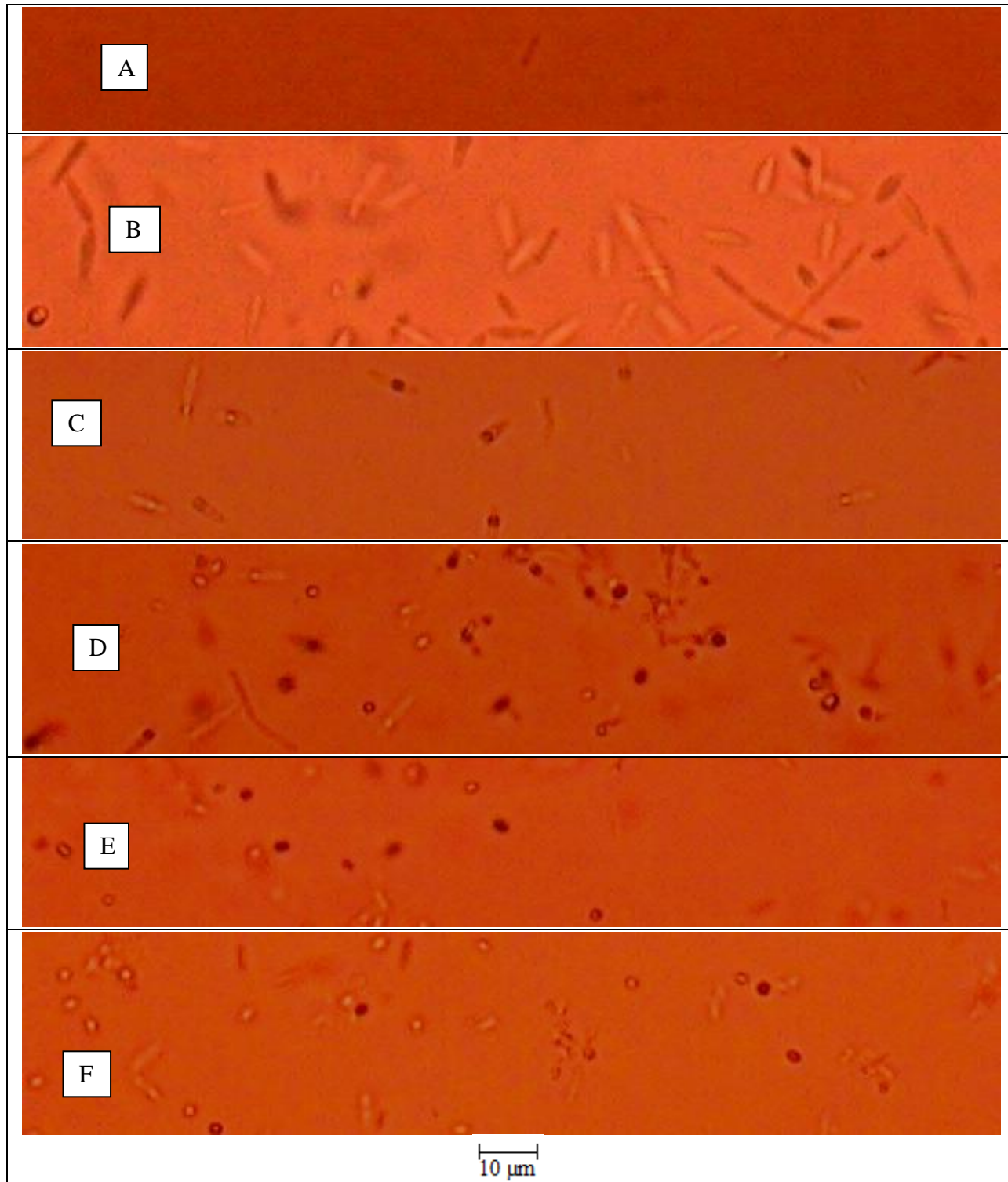

Figure 36 Microscopic images of *C. beijerinckii optonii* cultures in sugarcane juice medium at 12 hours (A), 24 hours (B), 36 hours (C), 48 hours (D), 72 hours (E) and 96 hours (F). Cells elongated slightly at 12 hours and spores formed by 12 hours. Spores increased until 72 hours post-inoculation

The consumption of total sugars was slower and lower during the fermentation of sugarcane juice medium than when only glucose was present in the medium. The majority of the initial sugar present was sucrose (91%). The initial sugar concentrations were 49.5 g/L sucrose, 2.5 g/L glucose and 2.3 g/L fructose. At 72 hours post-inoculation, 33.1 g/L sucrose, 1.3 g/L glucose and 1.3 g/L fructose were present. Figure 37 shows the concentrations of sugars present during the fermentation of sugarcane juice.

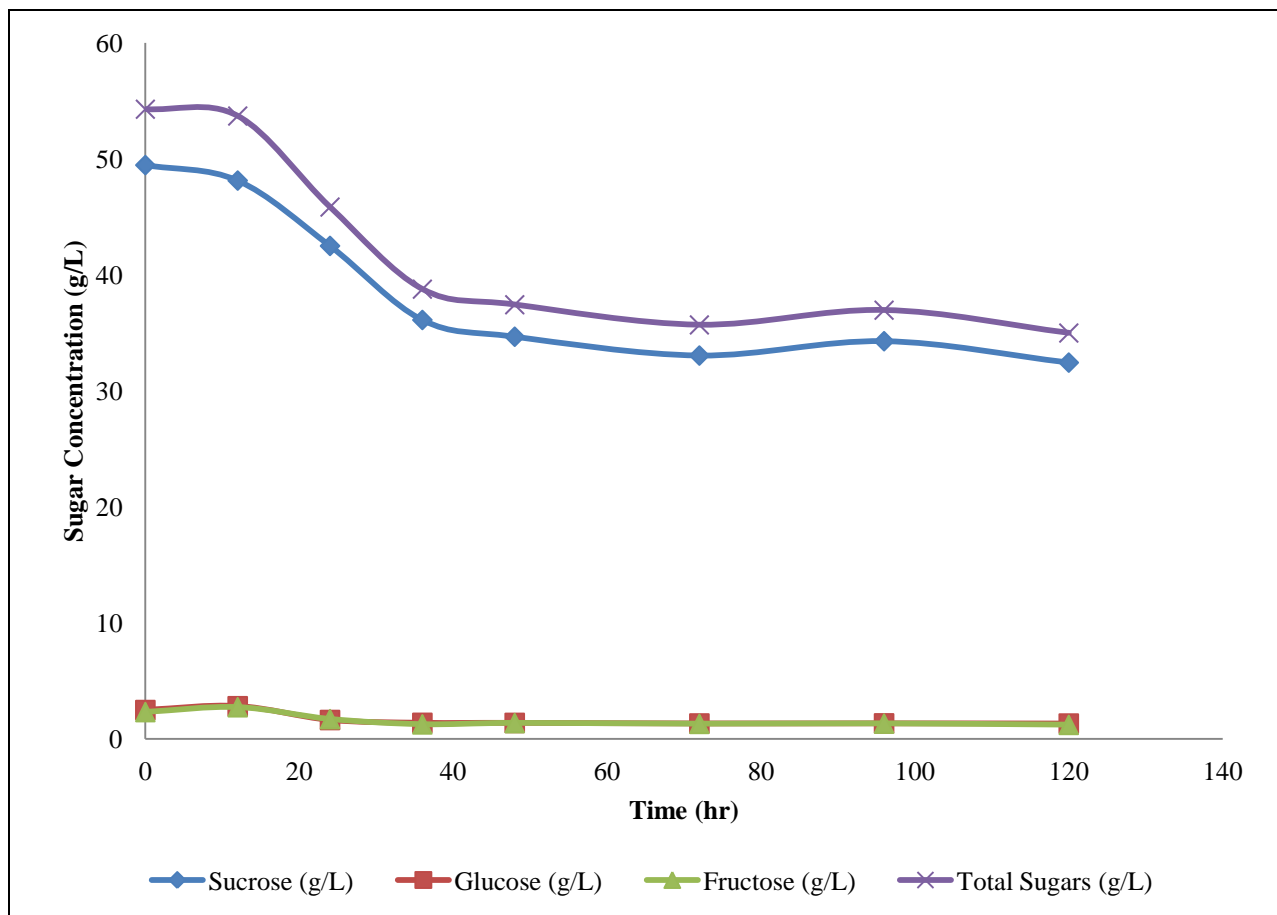

Figure 37 Concentrations of sugars during fermentation of sugarcane juice by *Clostridium beijerinckii optonii*

Production of butanol and solvents was also lower on sugarcane juice medium than on glucose medium. Figure 38 shows the total sugars, acids and solvents produced during the fermentation of sugarcane juice medium.

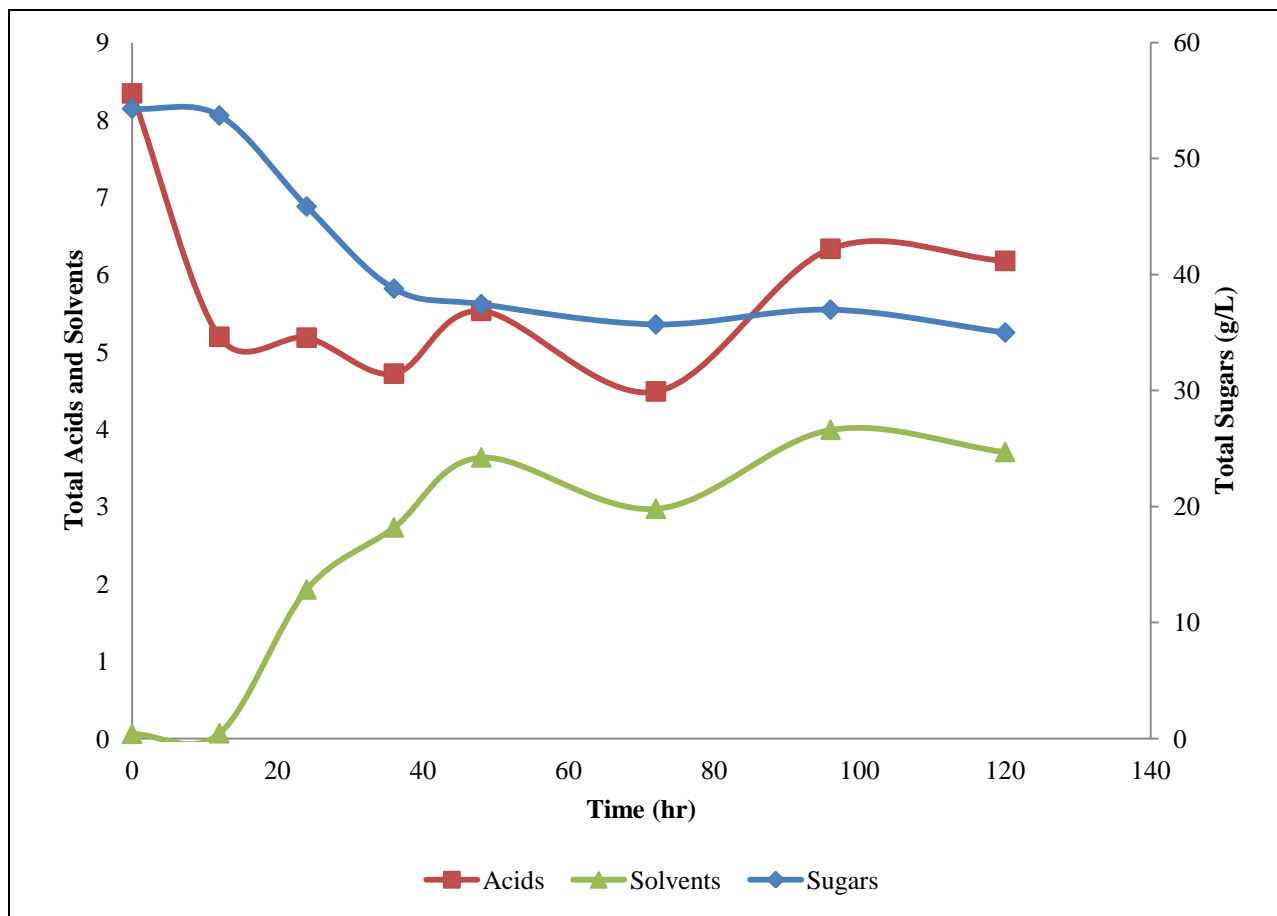

Figure 38 Total sugars, acids and solvents during the fermentation of sugarcane juice medium. Total sugars dropped from 54.3 g/L to 35.0 g/L in 120 hours. Acids dropped slightly from 8.3 g/L to 4.5 g/L by 72 hours and increased to 6.3 g/L by 96 hours. Total solvents reached 4.0 g/L by 96 hours

The total sugars dropped from 54.3 g/L (49.5 g/L sucrose) to 35.0 g/L (32.4 g/L sucrose) during the course of the 120 hour fermentation. The maximum concentration of solvents peaked at 4.0 g/L at 96 hours when 3.1 g/L butanol (77% of total solvents), 0.8 g/L 2-propanol (20% of total solvents), 0.1 g/L ethanol (2% of total solvents) and 0.1 g/L acetone (1% of total solvents) were produced. Figure 39 shows the concentrations of the individual solvents produced during the course of fermentation.

Of the original 54.3 g/L total sugars, The *C. beijerinckii optonii* culture was able to utilize only 35.5% of the sugars for fermentation. The consumption of 19.3 g/L sugars to

produce 3.1 g/L butanol gave a yield of 0.16 g butanol/g sugars. The maximum productivity of butanol occurred at 48 hours when the productivity was 0.06 g/(L x hr).

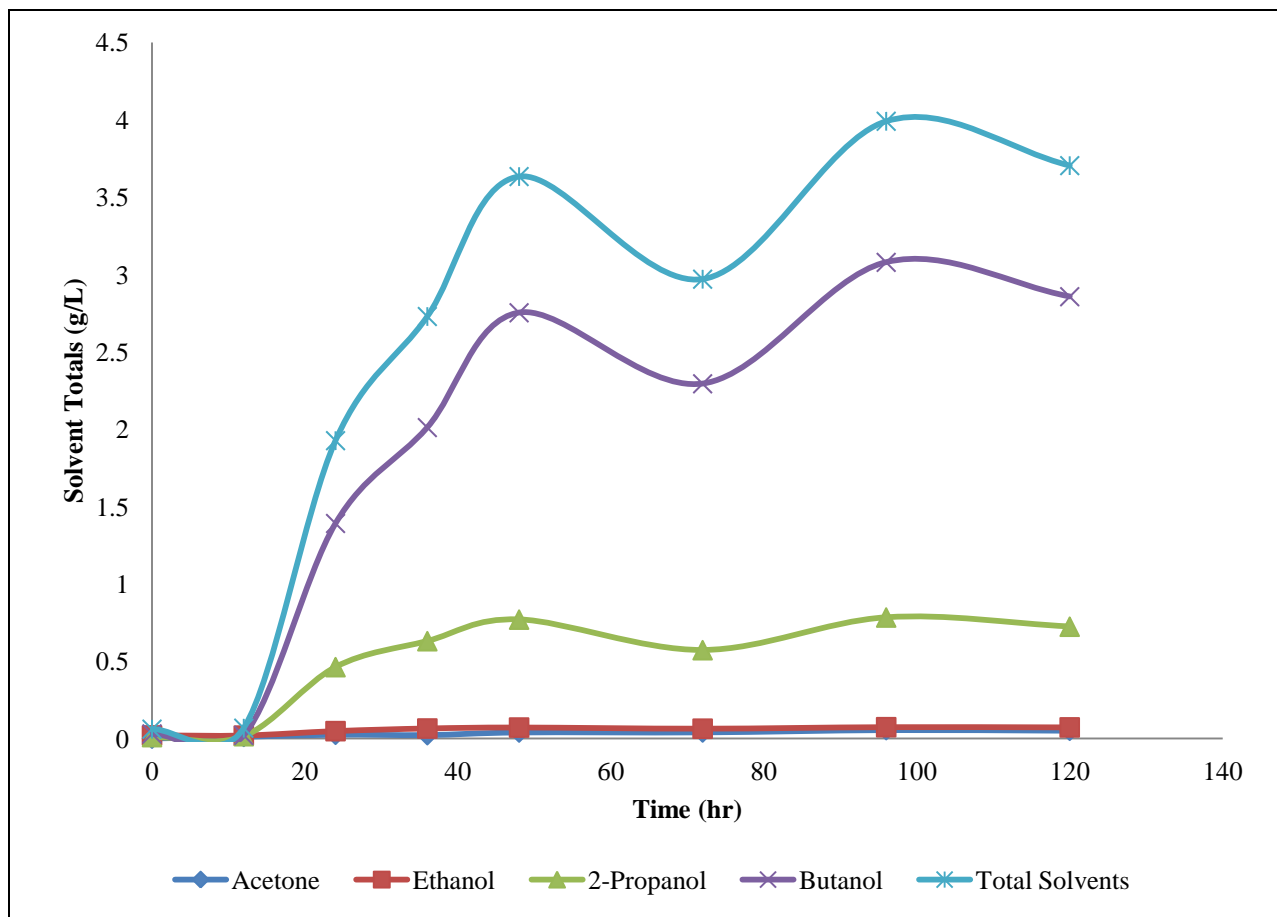

Figure 39 Profile of solvents produced during fermentation of sugarcane juice medium by *C. beijerinckii otonii*. The highest solvent output was found at 96 hours as 4.0 g/L total solvents were generated. The total solvents were composed of 3.1 g/L butanol, 0.8 g/L 2-propanol, 0.1 g/L ethanol and 0.1 g/L acetone

Molasses Fermentation

The fermentation of raw sugarcane blackstrap molasses with 38.2 g/L total sugars (29.4 g/L sucrose, 3.9 g/L glucose, 5.0 g/L fructose) had a slightly longer lag time than that which was seen in fermentations using glucose or sugarcane juice. After a 16 hour lag phase, the pH dropped from 5.9 to 5.6 over 8 hours. The pH settled at 5.6 until the end of the fermentation. The pH range fluctuation with molasses was narrower than fermentations of other feedstocks. The fluctuation of pH over time is shown in Figure 40.

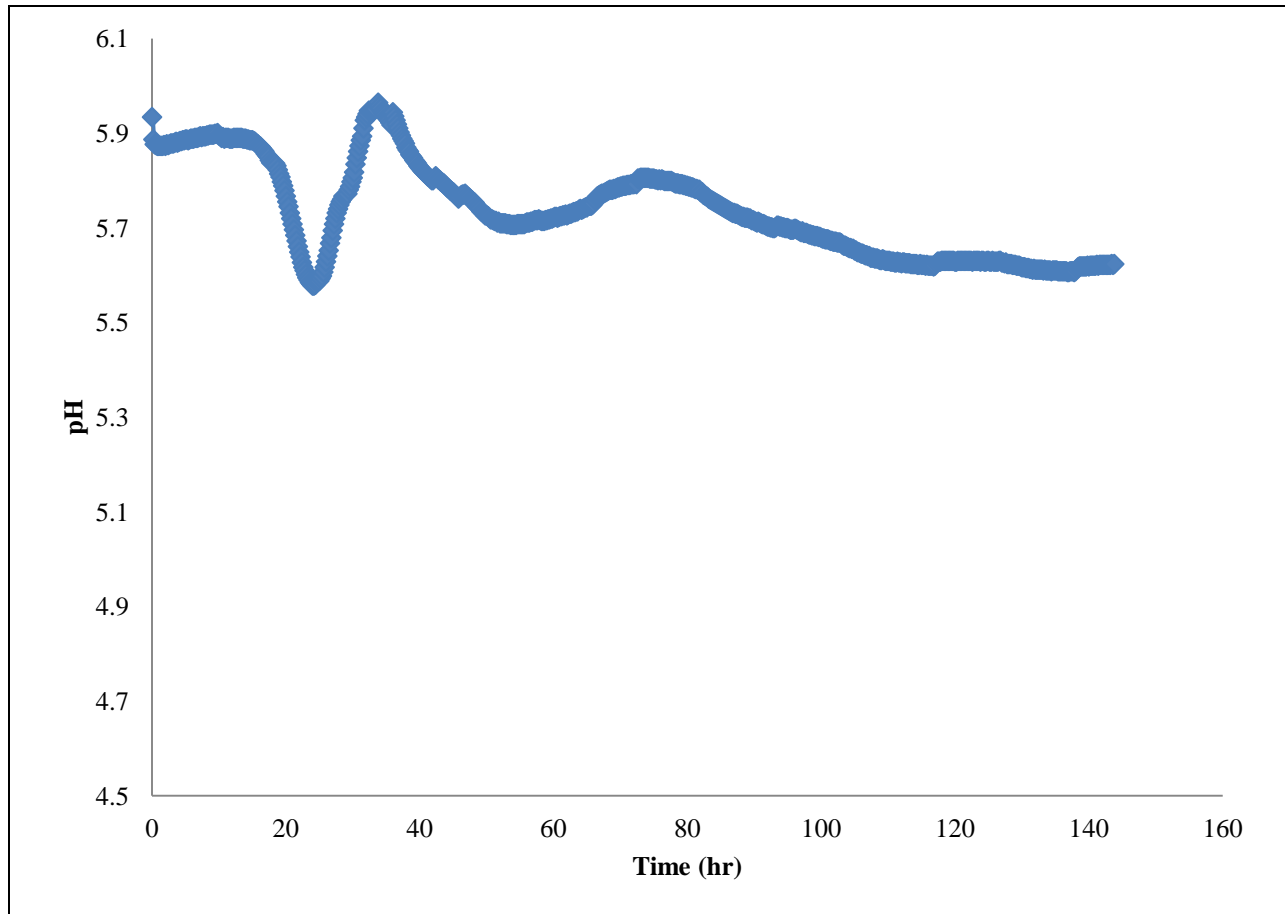

Figure 40 The change in pH over 144 hours of fermentation of 38.2 g/L sugarcane molasses medium by *C. beijerinckii optonii*. The pH curve had 2 dull peaks before settling at 5.6

After the lag period, the majority of the monosaccharides in the medium had been consumed by the *Clostridium* bacteria, only traces of glucose and fructose remained by 36 hours. The sucrose concentration continued to drop until 96 hours when the sugar consumption slowed. Sucrose consumption did not start until the majority of the monosaccharides were consumed. The consumption of the individual sugars over the course of fermentation is demonstrated in Figure 41.

As the sugars decreased from 38.3 g/L to 8.3 g/L, acetone, ethanol, 2-propanol and butanol were formed. The total solvents reached a concentration of 9.7 g/L by 96 hours with little change thereafter. Results from analysis of total sugars, acids and solvents are shown in Figure 42.

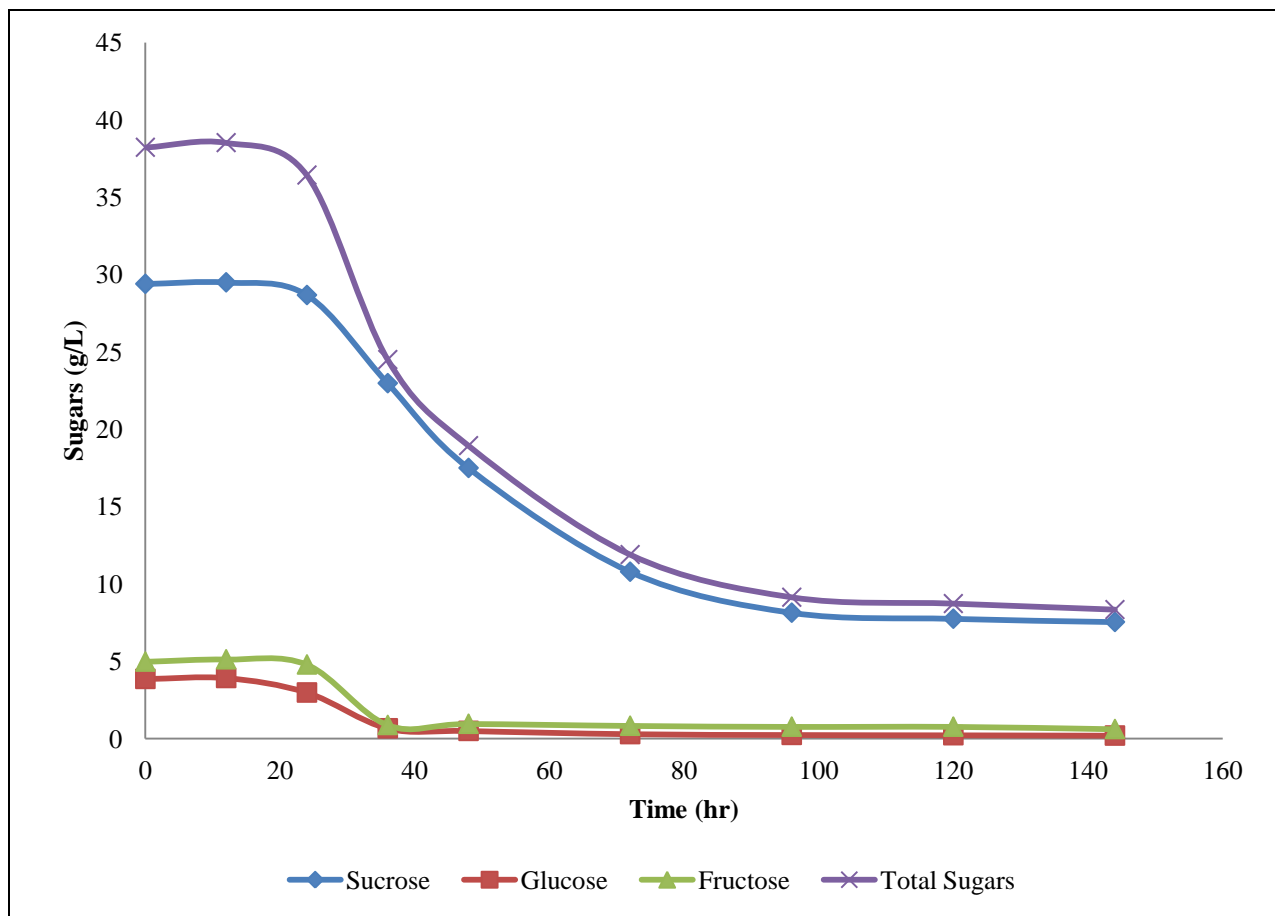

Figure 41 Individual sugars consumed by *C. beijerinckii optonii* in a fermentation of molasses medium containing 38.2 g/L fermentable sugar. The total sugar dropped from 38.2 g/L to 8.3 g/L in 144 hours. The combined glucose and fructose dropped from 8.8 g/L to 0.8 g/L during the fermentation

The solvents did not begin to form until 24 hours, when a rapid increase in solvents occurred from 24 to 36 hours. The concentration of solvents increased for the next 60 hours when the total concentration of solvents reached 9.7 g/L at a fermentation time of 96 hours. Of the 9.7 g/L total solvents, butanol was the most prevalent. The concentration of butanol at 96 hours was 6.5 g/L. The other solvents were 2-propanol (3.0 g/L), ethanol (0.1 g/L) and acetone (0.1 g/L). Results from the analysis of individual solvents are shown in Figure 43.

The maximum productivity of 0.10 g/L/hr butanol occurred at 48 hours. During the course of the fermentation, the *Clostridium* culture consumed 29.9 g/L sugar. The yield of butanol from the fermentable sugar was 0.21 g/g.

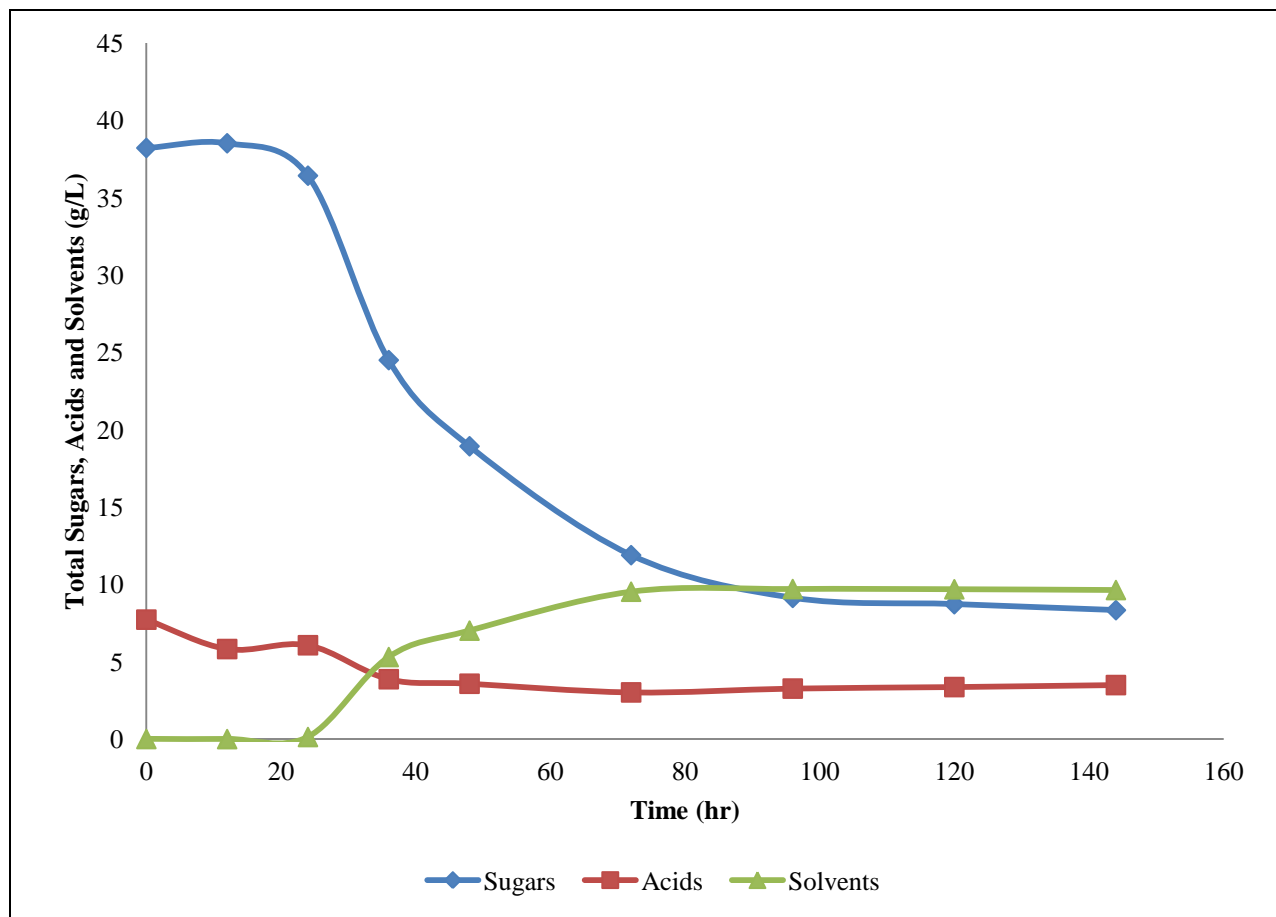

Figure 42 Total sugars, acids and solvents during the fermentation of 38.2 g/L fermentable sugar molasses medium using *C. beijerinckii optonii*. The total sugars dropped from 38.2 g/L to 8.3 g/L during the fermentation. The organic acids dropped from 7.7 g/L to 3.0 g/L by 72 hours and increased until 144 hours when they totaled 3.5 g/L. The total solvents increased until 96 hours when they totaled 9.7 g/L

Summary of Sugarcane Product Fermentations

The fermentation of pure glucose produced higher amounts of butanol, 2-propanol and total solvents than fermentations of sugarcane products. Fermentation of glucose in P2 medium produced 7.0 g/L butanol, 3.8 g/L 2-propanol and 11.5 g/L total solvents, fermentation of sugarcane juice in P2 medium produced 3.1 g/L butanol, 0.8 g/L 2-propanol and 4.0 g/L total solvents and fermentation of molasses in P2 medium produced 6.5 g/L butanol, 3.0 g/L 2-propanol and 9.7 g/L total solvents. Figure 44 shows the comparison of butanol and total solvent production in fermentations using glucose, sugarcane juice and sugarcane molasses.

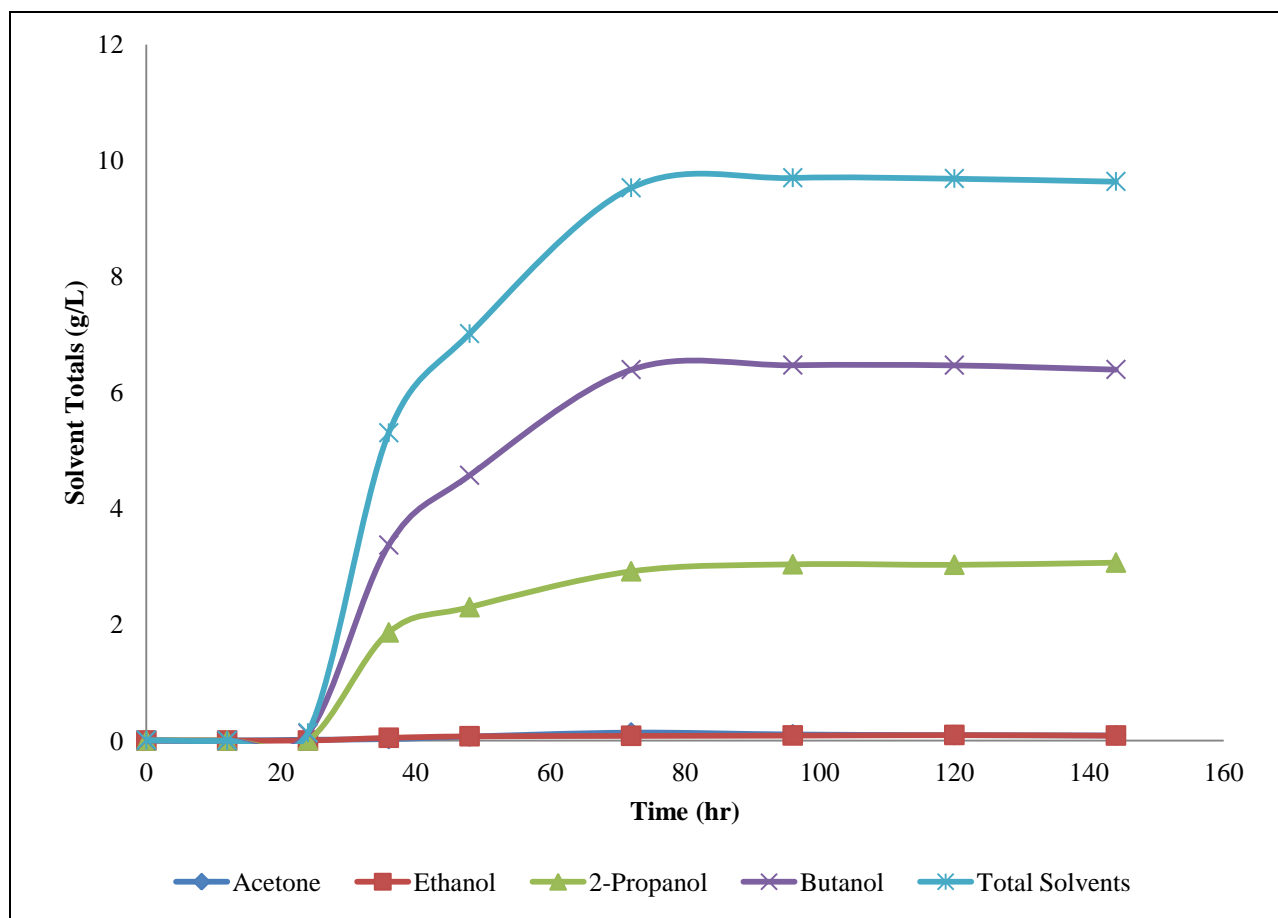

Figure 43 Solvents produced during fermentation of 38.2 g/L fermentable sugar molasses medium using *C. beijerinckii optonii*. The maximum amount of solvents was produced at 72 hours where they totaled 9.7 g/L. The composition of the total solvents was 6.5 g/L butanol, 3.0 g/L 2-propanol, 0.1 g/L ethanol and 0.1 g/L acetone

The production of butanol and solvents from fermentation of sugarcane juice were lower than that from glucose or molasses. The sugars in the sugarcane juice were primarily sucrose (91.1%). Only 4.8 g/L monosaccharides were present, whereas the molasses medium contained 8.8 g/L monosaccharides and 76.9% of the fermentable sugar was sucrose.

The slowest rate of fermentation was found in the fermentation of sugarcane juice medium, producing butanol at a rate of 0.06 g/L/hr. The fermentation of molasses medium produced butanol at a rate of 0.10 g/L/hr. The productivity of fermentation of glucose medium was higher than the other fermentations with a rate of 0.16 g/L/hr. Results of the productivity of each medium are shown in Figure 45.

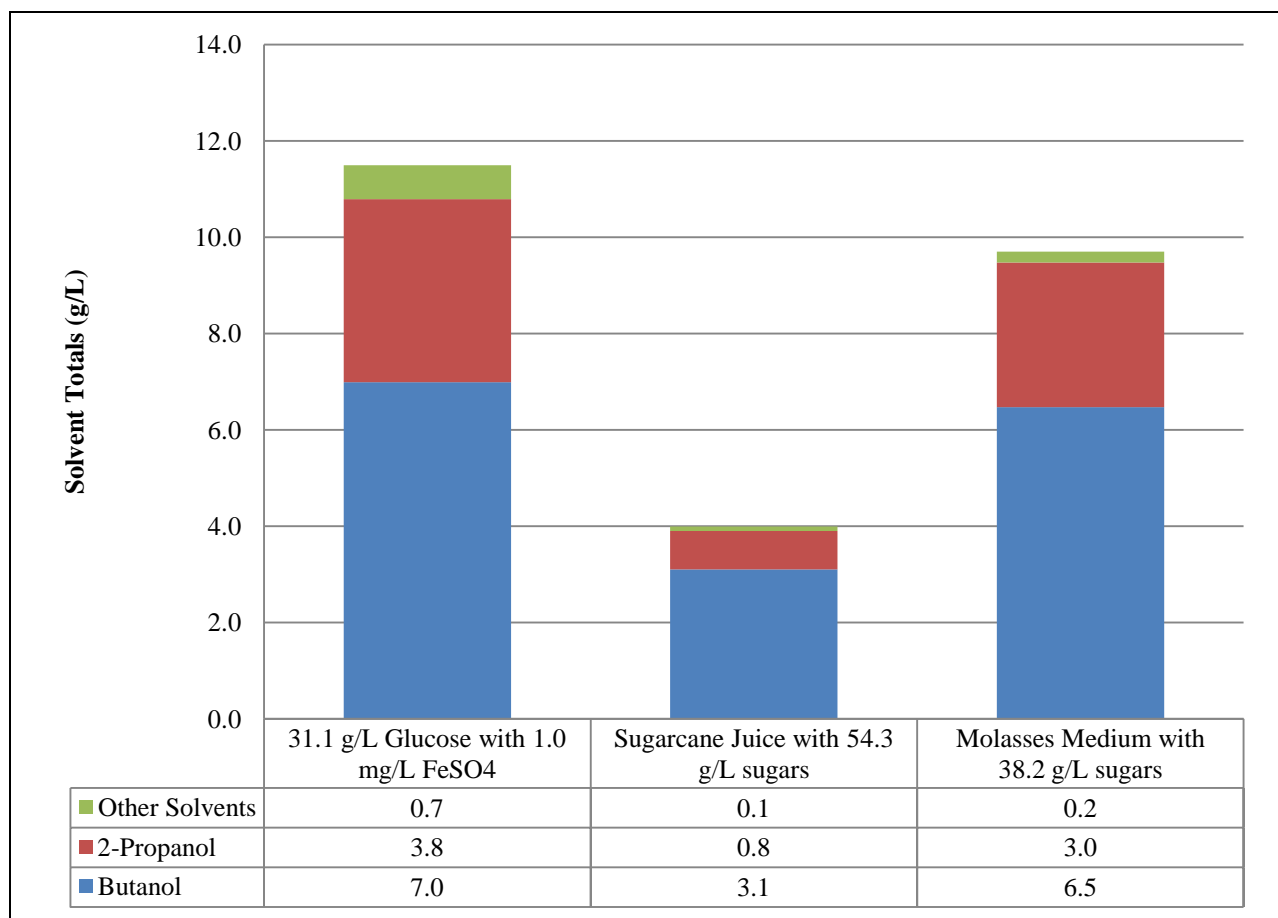

Figure 44 Comparison of butanol and total solvents produced in fermentations of glucose and sugarcane products

Not only was the consumption of sugar and productivity lower in fermentation of sugarcane juice than any other fermentation, but the yield was low as well at only 0.16 g butanol/g sugar, compared to the yield of 0.21 g/g using molasses medium and 0.33 g/g using glucose medium. Results of the yield of butanol from sugars are shown in Figure 46.

Immobilized Cell Culture

An immobilized *C. beijerinckii optonii* culture was run for 47 days at 36 °C using glucose medium, containing 25 g/L glucose, at flow rates ranging from 0.40 ml/min to 1.0 ml/min. A flow rate of 0.4 ml/min translates to a dilution rate of 0.1 hr⁻¹ and 1.0 ml/min translates to a dilution rate of 0.25 hr⁻¹. A contamination with yeast occurred after 47 days of continuous operation, at which time the bioreactor column was heated to 75°C for 10 minutes and then the

temperature returned to 36 °C. The culture was run for several days to allow it to return to equilibrium prior to continuing monitoring.

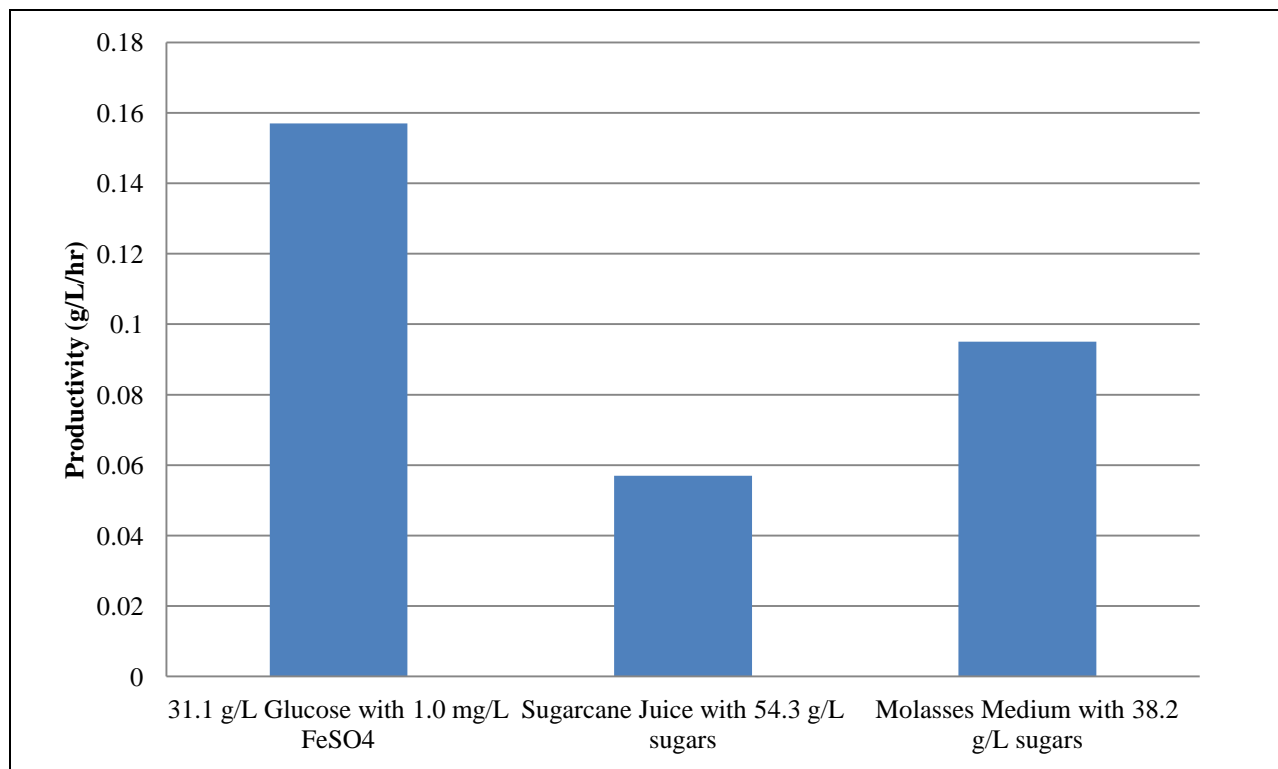

Figure 45 Productivity of fermentations using glucose and sugarcane products as substrates. The productivity was highest in the fermentation of glucose as 0.16 g/L/hr butanol was produced. The lowest productivity was achieved in the fermentation of sugarcane juice medium as 0.06 g/L/hr butanol was produced

The immobilized culture generated solvents and consumed glucose in a similar manner to the batch cultures. Table 12 summarizes the concentrations of solvents generated and sugars consumed at each flow rate for 25 g/L glucose in the 240 ml immobilized cell column.

The most butanol was produced from fermentation of 25 g/L glucose, when the flow rate through the column was 0.72 ml/min. The butanol production reached an average of 5.36 g/L. As with batch cultures, 2-propanol was the solvent produced with the second highest concentration at a flow rate of 0.72 ml/min or lower. When the flow rate was increased, and the dilution rate was decreased, the *C. beijerinckii optonii* cultures produced more acetone than 2-

propanol. Figure 47 shows the solvents produced during the continuous fermentation of 25 g/L glucose.

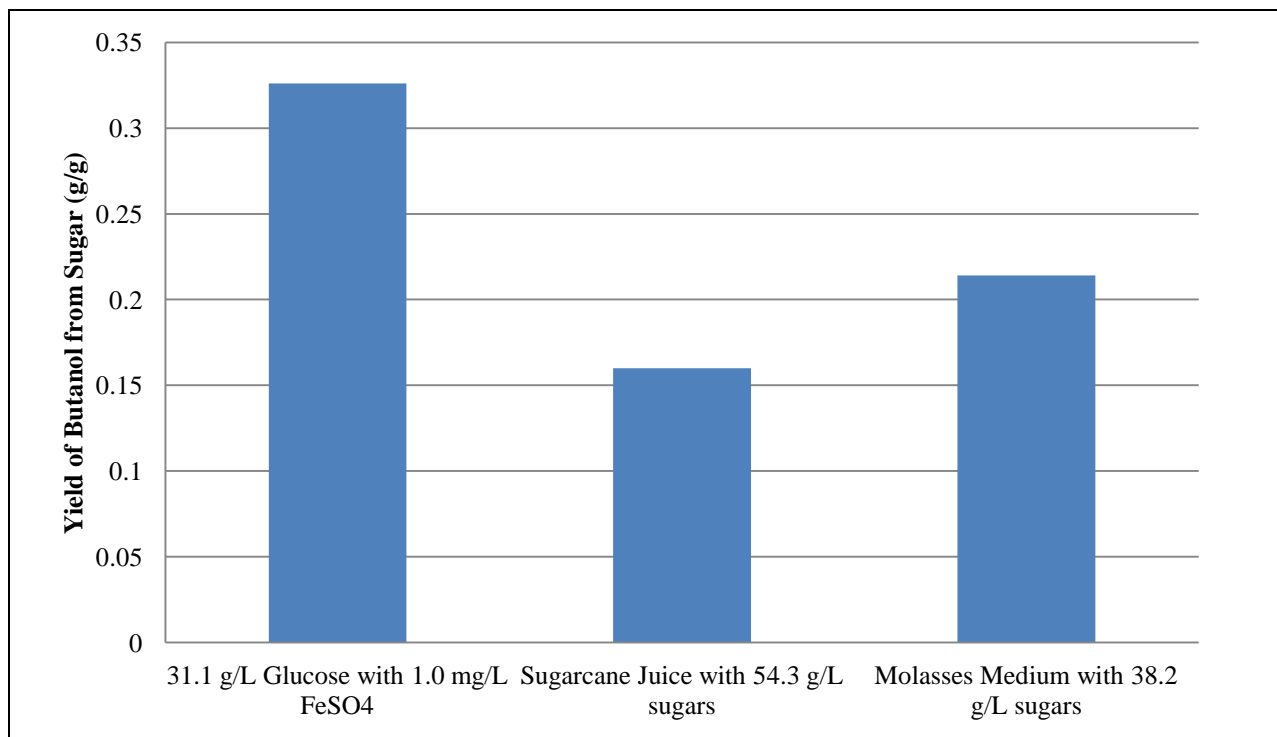

Figure 46 Yield of butanol produced per gram of sugar utilized in fermentations of glucose and sugarcane products. The yield of butanol per gram of sugar was highest using glucose medium as a yield of 0.33 was achieved whereas the lowest yield was found using sugarcane juice as the yield was 0.16

A dilution rate of 0.18 hr^{-1} was also the most efficient for total solvent production, butanol productivity in g/L/hr and conversion of butanol from glucose (g/g). Figure 48 shows the relation between dilution rate and butanol productivity. A butanol productivity of 0.97 g/L/hr was achieved at a dilution rate of 0.18 hr^{-1} . A sharp drop in butanol productivity was found when the dilution rate was increased or decreased from the optimum 0.18 hr^{-1} .

The yield of butanol from glucose was maximum at a dilution rate of 0.18 hr^{-1} at 0.308 g/g . A dilution rate of 0.15 hr^{-1} gave an average yield of 0.30 g/g . Yields of butanol produced per gram of glucose consumed dropped off sharply above a dilution rate of 0.15 hr^{-1} and below a

dilution rate of 0.18 hr⁻¹. Figure 49 shows the average yields of butanol per gram of sugar at the various dilution rates.

Table 12 Immobilized Culture Results for Fermentation of Glucose Media

Flow Rate (ml/min)	Dilution Rate (hr ⁻¹)	Glucose Consumed (g/L)	Average Butanol Produced (g/L)	Solvents Produced (g/L)	Butanol Conversion from Glucose (g/g)	Butanol Productivity (g/L/hr)
25 g/L Glucose Medium						
0.48 (n=5)	0.12	6.43 (±1.63)	1.22 (±0.92)	2.66 (±1.09)	0.176 (±0.084)	0.146 (±0.111)
0.60 (n=6)	0.15	11.44 (±1.11)	3.23 (±0.61)	4.97 (±1.09)	0.283 (±0.045)	0.485 (±0.091)
0.72 (n=6)	0.18	17.40 (±2.80)	5.36 (±0.95)	6.81 (±1.21)	0.308 (±0.014)	0.965 (±0.172)
0.80 (n=5)	0.2	10.54 (±0.97)	2.31 (±0.26)	3.80 (±0.41)	0.220 (±0.014)	0.463 (±0.052)
0.92 (n=4)	0.23	7.57 (±0.32)	1.25 (±0.13)	2.32 (±0.37)	0.165 (±0.018)	0.287 (±0.030)
1.00 (n=1)	0.25	6.38	0.82	1.68	0.129	0.205
30 g/L Glucose Medium						
0.40 (n=3)	0.1	18.95 (±2.17)	4.33 (±0.64)	7.37 (±1.58)	0.228 (±0.015)	0.433 (±0.064)
0.60 (n=3)	0.15	9.08 (±0.83)	1.41 (±0.20)	2.34 (±0.39)	0.158 (±0.037)	0.212 (±0.029)
0.72 (n=3)	0.18	9.85 (±0.50)	1.52 (±0.17)	3.12 (±0.24)	0.155 (±0.018)	0.274 (±0.030)
0.80 (n=3)	0.2	7.48 (±0.63)	1.03 (±0.02)	2.12 (±0.17)	0.138 (±0.010)	0.205 (±0.004)

The bacterial cells showed only slight morphological differences with flow rate. Similar to the glucose fermentation with 2.0 mg/L iron sulfate, none of the samples had developed spores. Figure 50 shows microscopic images of four samples at different dilution rates in the immobilized cell culture.

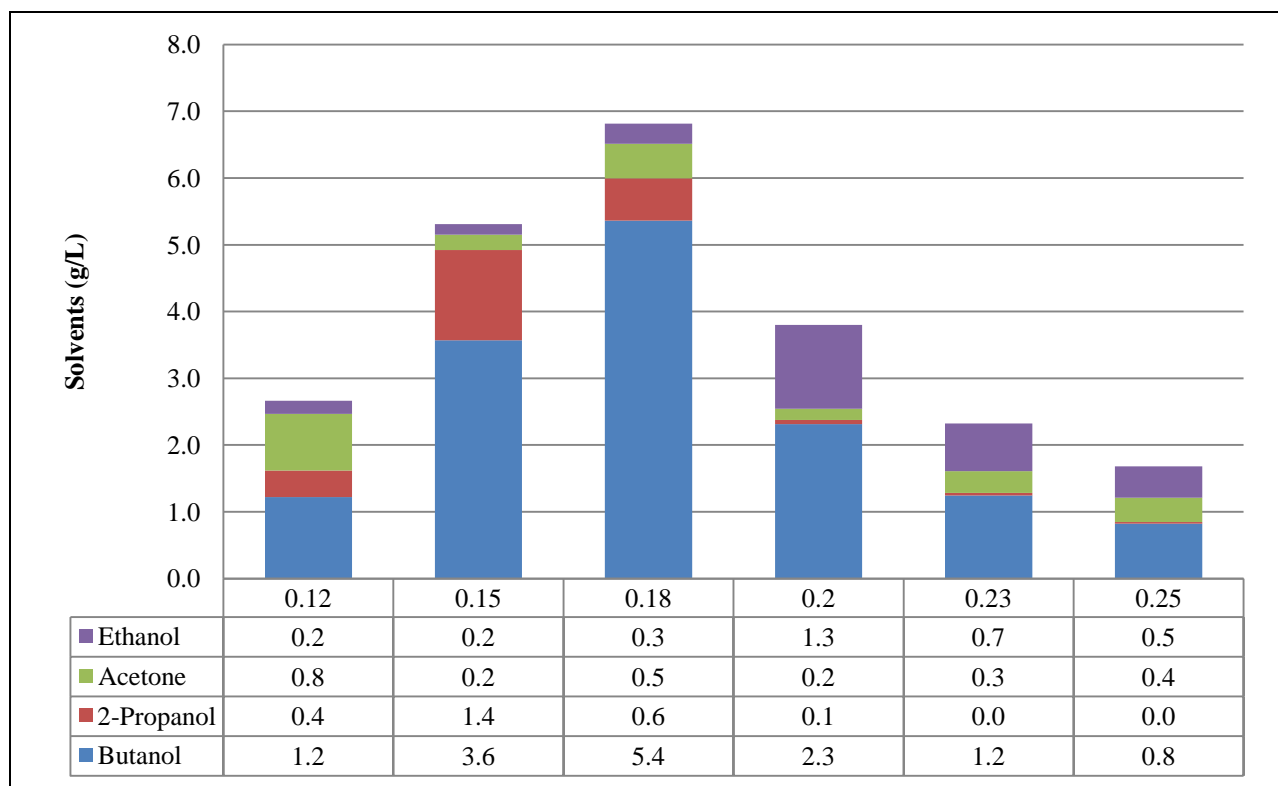

Figure 47 Solvents produced by *C. beijerinckii optonii* in an immobilized continuous fermentation of 25 g/L glucose medium at various dilution rates. A dilution rate of 0.18 hr⁻¹ gave the highest production as 6.8 g/L total solvents and 5.4 g/L butanol were produced

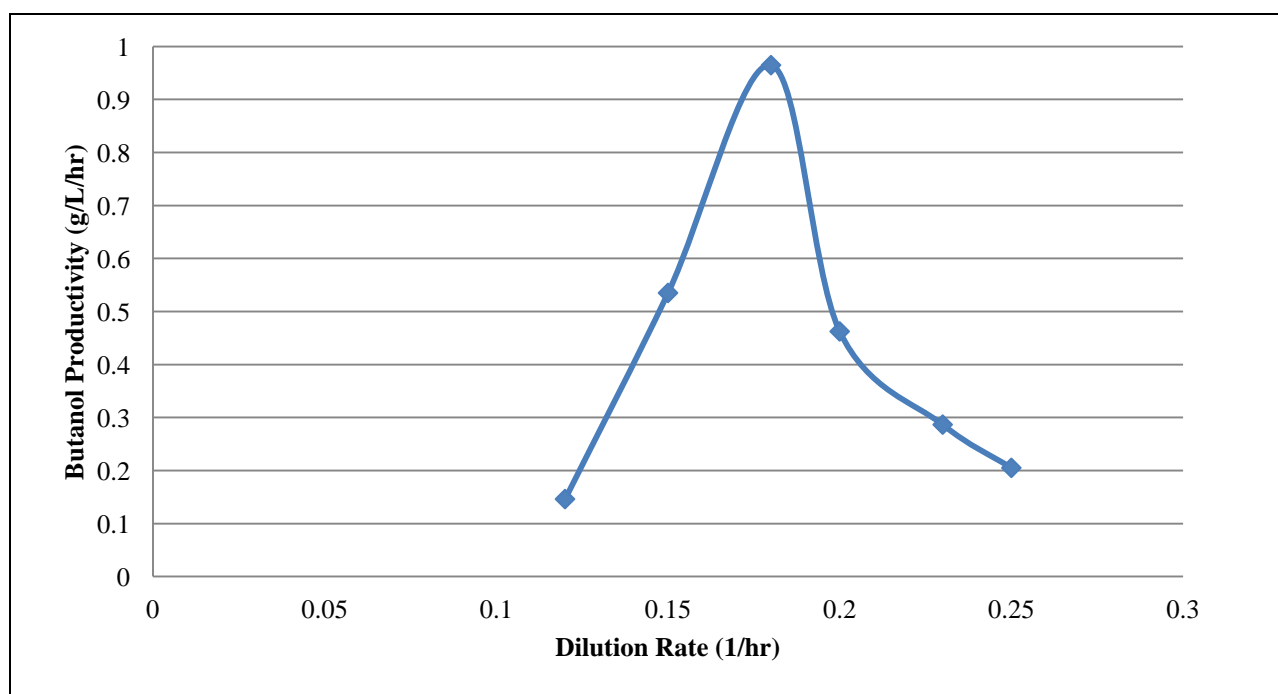

Figure 48 Butanol productivity by *C. beijerinckii optonii* in an immobilized continuous fermentation of 25 g/L glucose medium at various dilution rates. A dilution rate of 0.18 hr⁻¹ gave the highest productivity of butanol at 0.97 g/L/hr

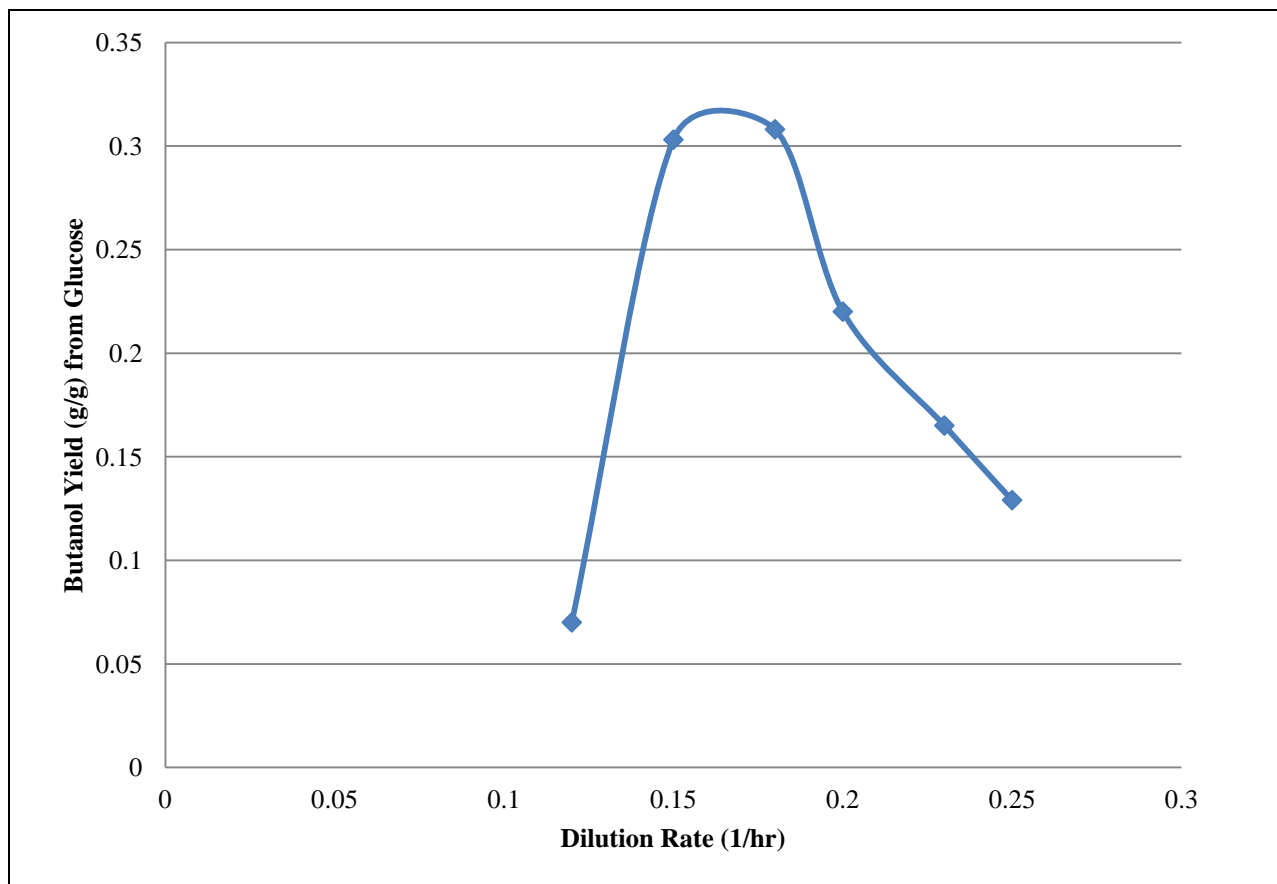

Figure 49 Average yields of butanol per gram of glucose by an immobilized culture of *C. beijerinckii optonii* at different dilution rates in a continuous fermentation of 25 g/L glucose medium. A dilution rate of 0.18 hr^{-1} gave a yield of 0.31 g/g and a dilution rate of 0.15 hr^{-1} gave a yield of 0.30 g/g

With a concentration of 30 g/L glucose the solvent profiles changed in comparison to 25 g/L glucose. The highest butanol and total solvents were produced at a dilution rate of 0.1 hr^{-1} with 4.33 g/L butanol and 7.37 g/L total solvents produced. Dilution rates higher than 0.1 hr^{-1} caused much lower production of solvents. Figure 51 shows the solvent production from the immobilized culture with a fermentation medium containing 30 g/L glucose.

The highest yield of butanol per gram of sugar was found using the slowest flow rate in a fermentation of 30 g/L glucose medium in the immobilized culture column. The yield at a dilution rate of 0.1 hr^{-1} gave a yield of 0.23 g/g whereas the yield sharply dropped off at faster

flow rates. Figure 52 shows the yields of butanol at various dilution rates with 30 g/L glucose medium in the immobilized cell column.

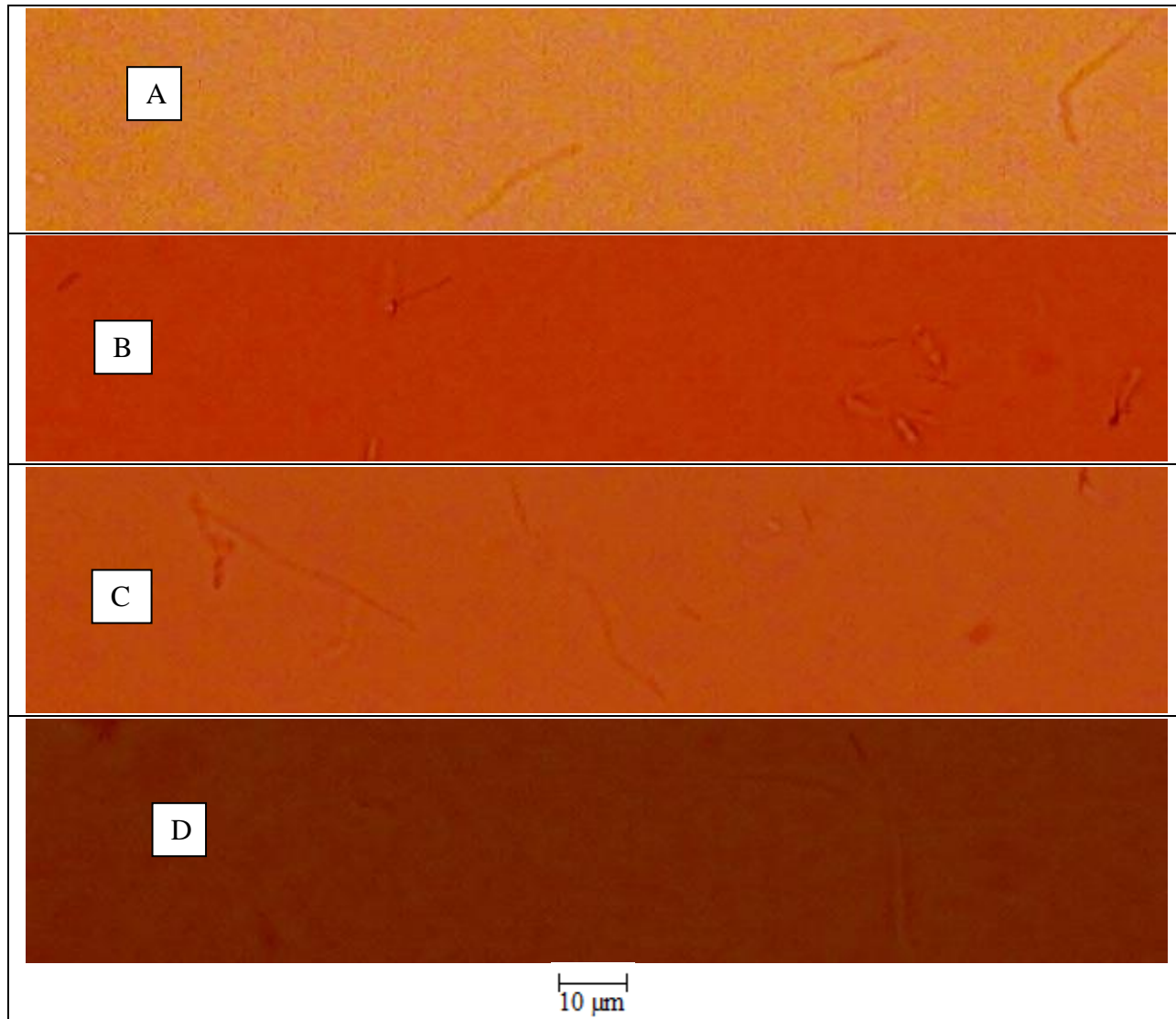

Figure 50 Microscopic images of samples from the continuous fermentation of 25 g/L glucose by *C. beijerinckii optonii* at dilution rates of 0.12 hr^{-1} , 0.18 hr^{-1} , 0.2 hr^{-1} and 0.23 hr^{-1} . The cells were elongated in all samples and did not form spores.

As with solvent production, productivity of butanol in a fermentation of 30 g/L glucose medium in an immobilized cell column increased at lower dilution rate. A dilution rate of 0.1 hr^{-1} provided the highest butanol productivity of 0.43 g/L/hr whereas faster flow rates had a sharp

decrease in productivity below 0.3 g/L/hr. Results of the productivity at various flow rates of 30 g/L glucose in the immobilized cell column are shown in Figure 53.

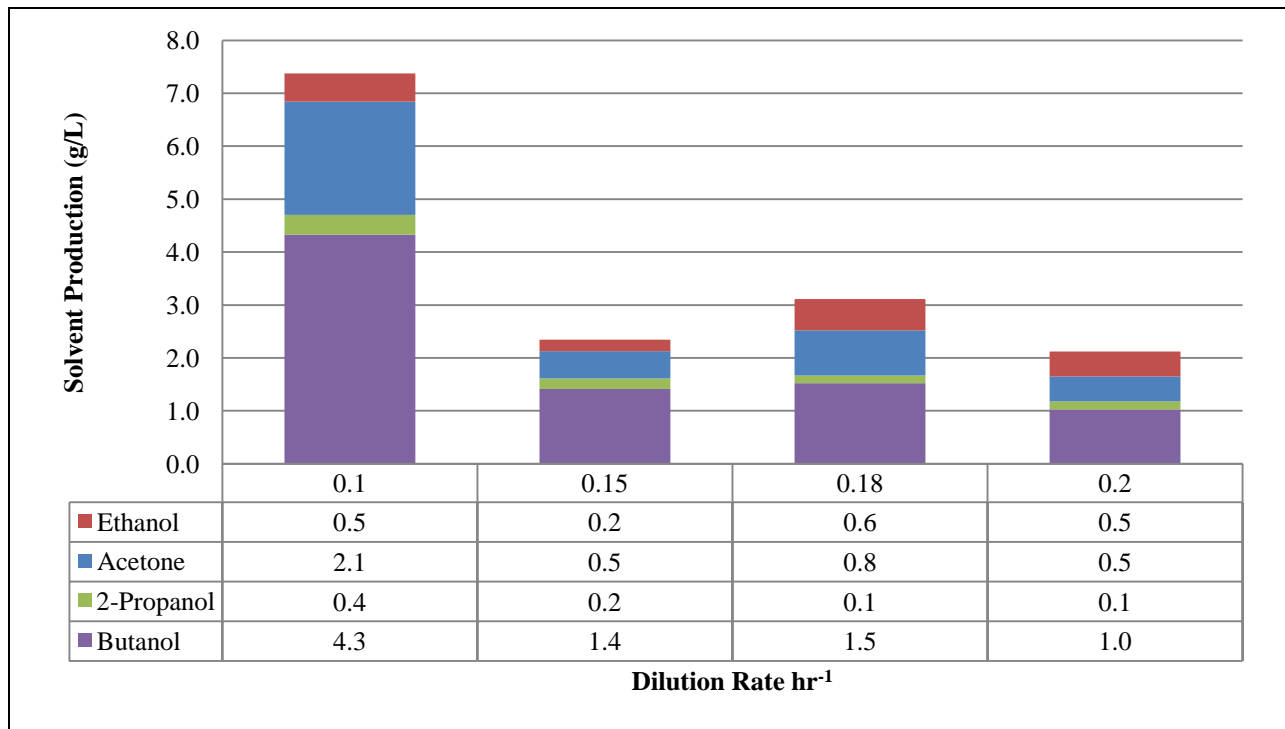

Figure 51 Solvents produced by the fermentation of 30 g/L glucose in the immobilized culture of *C. beijerinckii optonii* at dilution rates of 0.1 hr⁻¹, 0.15 hr⁻¹, 0.18 hr⁻¹ and 0.2 hr⁻¹. The slowest dilution rate (0.1 hr⁻¹) gave the highest yield of butanol (4.3 g/L) and total solvents (7.4 g/L)

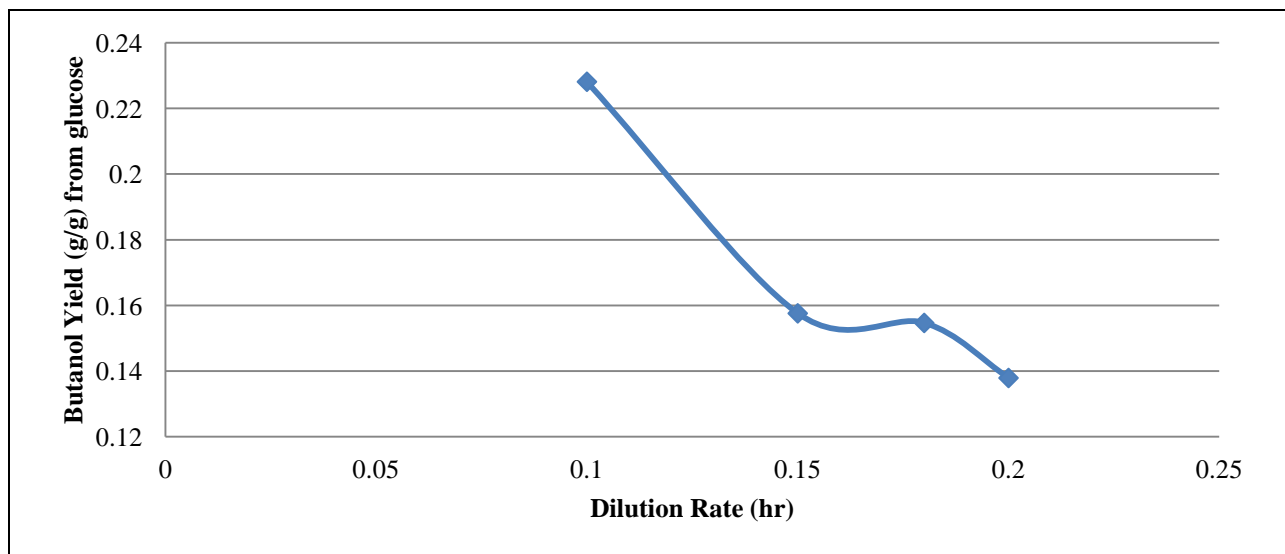

Figure 52 Butanol yield from glucose in fermentation of 30 g/L glucose medium using immobilized *C. beijerinckii optonii* culture. The highest butanol yield was achieved using a dilution rate of 0.1 hr⁻¹ as the yield was 0.228 g/g. Faster dilution rates showed a downward trend in butanol yield

The concentration of glucose at 45 g/L caused the production of butanol to drop far below the concentrations of butanol produced with 25 g/L or 30 g/L glucose in the media. The conversion rates of butanol from glucose were lower than 0.05 g/g for each of the flow rates tested.

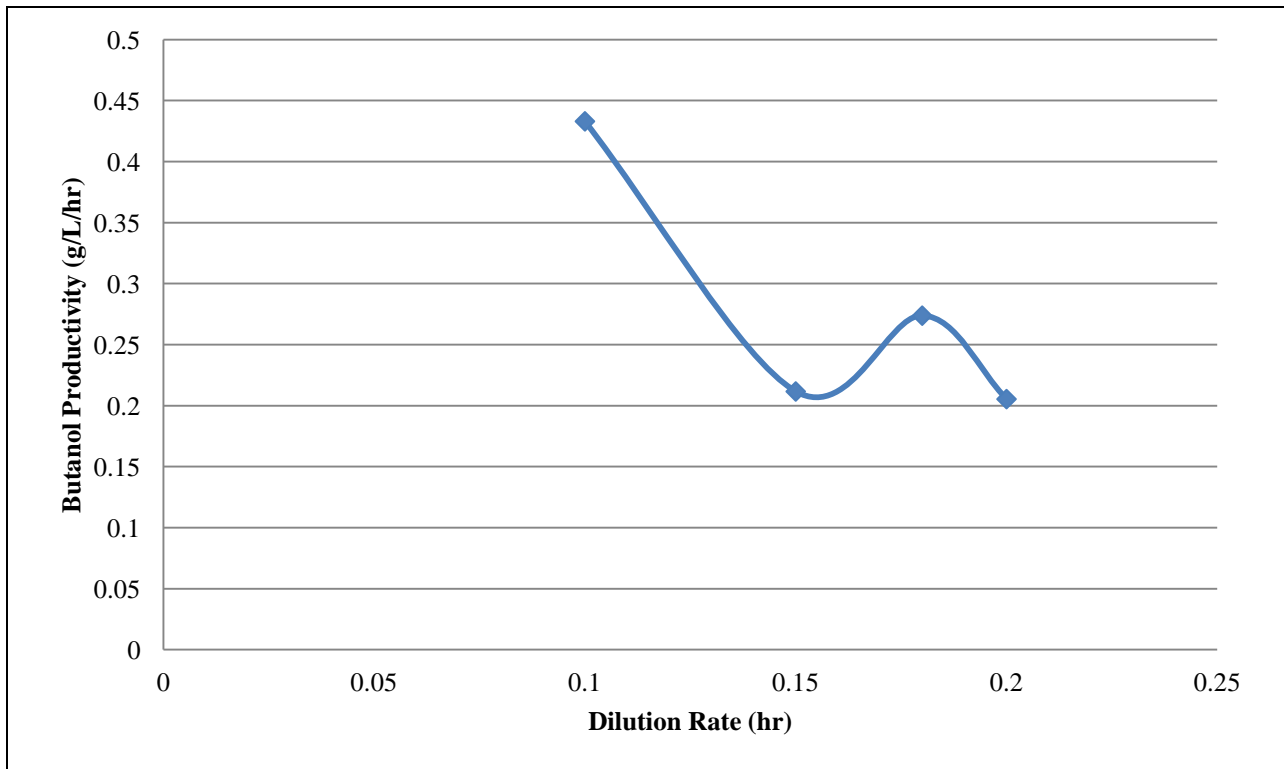

Figure 53 Productivity of butanol in the immobilized cell column using 30 g/L glucose medium at various dilution rates. The highest productivity was achieved by the slowest dilution rate as a dilution rate of 0.1 hr^{-1} yielded 0.433 g/L/hr butanol. Increased flow rates decreased productivity of butanol

V. DISCUSSION

C. beijerinckii optonii Classification

Unlike most *C. beijerinckii* strains, the strain tested in this study was unable to utilize xylose for solvent production. The fluctuations in pH seen throughout fermentation was different than that reported for other solventogenic *Clostridium* species. Furthermore, the strain used in this study produces a secondary alcohol dehydrogenase that converts acetone to 2-propanol, similar to that found in *C. acetobutylicum* Rh8 strain (Dai et al, 2012). These unique fermentation properties lead to the conclusion that the strain tested is a unique microorganism.

The production of 2-propanol serves three possible purposes to the *Clostridium* bacteria. The most obvious advantage of converting the acetone to 2-propanol is that acetone is more toxic to the organism than 2-propanol. The reduction of acetone to 2-propanol regenerates NAD(P)^+ which helps maintain an electrochemical balance. The conversion of NAD(P)H to NAD(P)^+ also decreases the acidity of the fermentation broth, which in turn helps decrease the passage of undissociated butyric acid into the cell, improving the effectiveness of the enzymes within the cell.

This organism lost its ability to convert acetone to 2-propanol as the pH dropped below 4.6. The increased amounts of acetone in the final broth of the immobilized continuous culture indicated that *C. beijerinckii optonii* cells either mutated causing underexpression of the alcohol dehydrogenase enzyme causing cessation of 2-propanol production or more likely the pH dropped below the optimal range for alcohol dehydrogenase functioning.

An obvious difference in the metabolism of *Clostridium beijerinckii optonii* to other solventogenic *Clostridium* strains is shown by the pH curve during fermentation. Research on butanol production by *Clostridium* species explain the two distinct phases to fermentation in which the pH drops as acids build up and rises as solvents are generated (Nair et al, 1999,

Ravagnani et al, 2000). The pH curves of all fermentations showed multiple peaks and valleys as the culture simultaneously generated acids and solvents. Previous reports indicate that other cultures normally do not generate acids when solventogenesis begins (Nari et al, 1999), rather solventogenesis is coupled with sporulation (Patakova et al, 2013, Ravagnani et al, 2000). As shown in glucose fermentation in the presence of 2.0 mg/L $\text{FeSO}_4 \cdot 7\text{H}_2\text{O}$, solventogenesis can occur without production of Clostridial spores in this strain. In conjunction with the sugar utilization patterns, this indicates that the strain was originally misclassified and should be classified as a new strain *C. beijerinckii optonii*.

Fermentation of Glucose in the Presence of Differing Amounts of $\text{FeSO}_4 \cdot 7\text{H}_2\text{O}$

Research on the effects of iron concentration in fermentation media during fermentation using *Clostridium* bacteria have generally shown that increasing amounts of $\text{FeSO}_4 \cdot 7\text{H}_2\text{O}$ increases productivity during fermentation. Production of biohydrogen by *C. acetobutylicum* can be increased by addition of up to 25 mg/L (0.09mM) $\text{FeSO}_4 \cdot 7\text{H}_2\text{O}$, but hydrogen production decreases as the concentration of $\text{FeSO}_4 \cdot 7\text{H}_2\text{O}$ was increased beyond 0.09mM (Alshiyab et al, 2008). Iron is used as a cofactor in some enzymatic reactions. While small increases in iron content can help increase the efficiency of fermentation using *Clostridium* bacteria, other divalent metal cofactors have not been shown to aid in fermentation to produce hydrogen (Alshiyab et al, 2008). Increasing the concentrations of calcium and magnesium decreased the output of hydrogen (Alshiyab et al, 2008).

The concentration of $\text{FeSO}_4 \cdot 7\text{H}_2\text{O}$ was reported to have a minimal effect on the output of butanol by an unknown strain of *Clostridium* bacteria in comparison to other factors such as glucose, yeast extract, sodium carbonate, MgSO_4 , tryptone or peptone concentration (Al-Shorgani et al, 2013). These findings were similar to the findings in this study as very little

correlation was found between $\text{FeSO}_4 \cdot 7\text{H}_2\text{O}$ concentration and butanol production in fermentations not exhibiting acid crash. While little contribution to the production of butanol fermentation can be attributed to FeSO_4 , there is a positive correlation between higher concentrations of iron sulfate and higher amounts of butanol. The difference seen in results from this study and the Al-Shorgani et al (2013) study could be due to different strains of *Clostridium* or the composition of the other constituents in the media used. A lack of correlation between 4 different levels of FeSO_4 in the fermentation medium was found in this study. The range of $\text{FeSO}_4 \cdot 7\text{H}_2\text{O}$ was between 0.5 mg/L (1.8 μM) and 2.0 mg/L (7.2 μM) in this study. In the study by Al-Shorgani (2013), the two concentrations tested were from 3.6 μM and 0.36mM.

Explanation of the Acid Crash

The two trials in which the pH dropped below 4.80 produced solvents, though they were lower than productivity compared to other glucose fermentations as well. The low productivity of solvents can be explained by “acid crash,” or the theory that if the pH drops too quickly, the bacteria cannot recover and switch to the solventogenesis phase of fermentation in order to raise the pH of the medium (Maddox et al, 2000). Acid crash typically causes low solvent productivity in fermentations, which may be the result of the intracellular pH dropping out of the optimum range of the enzymes used to produce solvents. Though the most common acids produced during fermentation are acetic acid and butyric acid, the acid crash can be caused by a build-up of any acids found in the medium (Wang et al, 2011).

The acid crash fermentation with 2.0 mg/L $\text{FeSO}_4 \cdot 7\text{H}_2\text{O}$ present in the P2 medium had the lowest pH of any fermentation. That fermentation did not form spores, whereas the other acid crash fermentation with 0.5 mg/L $\text{FeSO}_4 \cdot 7\text{H}_2\text{O}$ did sporulate.

Aside from the inactivation of enzymes within the cell, acid crash can also be explained by the toxicity of *Clostridium* bacteria to undissociated butyric acid. Butyric acid is a microbial inhibitor, especially when the pH is below 4.8, the pKa value for butyric acid (Richter et al, 2012). Undissociated butyric acid can diffuse across the cell membrane of *Clostridium* bacteria where it dissociates inside the cell because the pH of the cytoplasm is higher than that of the extracellular matrix, causing the release of protons within the cell and trapping dissociated butyrate inside the cytoplasm.

Microscopic images of the *C. beijerinckii optonii* cells during the course of each fermentation shows that the cells are more elongated and thinner at low pH. This is likely a physiological response to the undissociated butyric acid by increasing surface area and decreasing the volume within the cell to avoid the acid crash. The increased surface area may help in expelling the acids trapped within the cell as a survival mechanism.

The switch from the acidogenesis phase of fermentation to the solventogenesis phase is often attributed to the need to balance NAD(P)^+ and NAD(P)H . As anaerobic organisms, Clostridia are unable to utilize the electron transport system to recycle NAD^+ . The acidogenesis phase generates an imbalance in the $\text{NAD(P)}^+/\text{NAD(P)H}$ ratio. An increase in NAD(P)H generates an oxidoreduction potential (ORP). A study by Wang et al (2012) showed that the “acid crash” can be averted by controlling the ORP in *C. acetobutylicum*. The concentration of butanol produced by in batch fermentations could be increased by controlling the ORP at -290 mV. The butanol production in a batch with no ORP control produced 11.8 g/L butanol, whereas fermentation with ORP set at -290 mV produced 16.8 g/L butanol. The final concentration of butanol decreased in comparison to the uncontrolled batch when the ORP was set at -260 mV or -350 mV.

Unfortunately, there is little explanation why acid crash occurred in two of the fermentations in this study. The two acid crash fermentations had similar conditions to fermentations not exhibiting acid crash. These unusual occurrences are not likely to be caused from any internal components of the media or the conditions of fermentation.

Fermentations Using Sugarcane Juice and Sugarcane Molasses

Sugarcane juice contains both thiamine and biotin, two of the vitamins provided in P2 media. Louisiana cane juice provides an average of 0.90 $\mu\text{g/g}$ thiamine and 0.030 $\mu\text{g/g}$ biotin (Jackson and Macek, 1944). It would be assumed based on the vitamin content of sugarcane, fermentations using sugarcane juice and molasses would produce higher amounts of butanol than fermentation of pure glucose. However, with little invertase expressed by most strains of *Clostridium* bacteria, the ability to ferment sucrose is limited and productivity is low (Shaheen et al, 2000). Fermentations using substrates whose main component is sucrose typically take longer than fermentations utilizing monosaccharides such as glucose or fructose. This inability to readily utilize sucrose was apparent in the fermentations of sugarcane juice and sugarcane molasses.

Though the concentration of carbohydrate was high, the total carbohydrate consumed was relatively low in fermentation of cane juice. Of the 54.3 g/L total sugars present, only 19.3 g/L (36%) of sugars were consumed to produce only 3.1 g/L butanol and 4.0 g/L total solvents.

In the molasses medium there were higher amounts of glucose and fructose than sugarcane juice medium, although sucrose was still the predominant carbohydrate with 76.9% of the sugar in the molasses medium being sucrose. A total of 29.39 g/L sucrose and 8.82 g/L monosaccharides were present in the molasses medium. As a result of a higher concentration of

monosaccharides, the fermentation of the initial 38.22 g/L total sugars utilized 29.88 g/L (78%) sugar to produce 6.47 g/L butanol and 9.70 g/L total solvents.

Not surprisingly, the fermentation of sucrose required longer fermentation time and media containing larger amounts of sucrose produced butanol at slower rates than fermentations with higher amounts of monosaccharides.

Previous research on the fermentation of sugarcane molasses using *C. saccharobutylicum* showed that butanol and total solvent concentrations of 11.9 g/L and 17.9 g/L, respectively, can be achieved in 36 hours of fermentation with an initial 60.0 g/L sugar content (Ni et al, 2012).

Sugarcane products contain significant quantities of minerals including iron, magnesium and manganese. The average iron content in blackstrap molasses in Pakistan averages 112.8 $\mu\text{g/g}$ ($2.02\mu\text{M}$) (Waheed and Ahmad, 2008). The average magnesium content is 235 $\mu\text{g/g}$ ($9.67\mu\text{M}$) and manganese content averages 18.4 $\mu\text{g/g}$ ($0.33\mu\text{M}$) (Waheed and Ahmad, 2008). In the 116.28 grams of molasses used to make 1.5L fermentation medium, the contribution of iron, magnesium and manganese from the molasses were 8.74 mg/L, 18.2 mg/L and 1.43 mg/L, respectively. The P2 medium provides 1 mg/L $\text{FeSO}_4 \cdot 7\text{H}_2\text{O}$ ($0.2008 \text{ mg/L Fe}^{2+}$), 20 mg/L $\text{MgSO}_4 \cdot 7\text{H}_2\text{O}$ ($1.972 \text{ mg/L Mg}^{2+}$) and 1 mg/L $\text{MnSO}_4 \cdot \text{H}_2\text{O}$ ($0.325 \text{ mg/L Mn}^{2+}$), so the mineral contributions from molasses are far above that of P2 supplementation.

Immobilized Continuous Fermentation

The immobilized cell reactor showed a decrease in productivity after 55 days. The pH of the broth had dropped lower than the pH found in batch fermentations, decreasing production of butanol. A buildup of solvents in the column may have caused an increase in acid production, changing the metabolism within the immobilized culture. The acid buildup occurred as the dilution rate increased, which may indicate that the culture was metabolizing faster than the

solventogenic conversion could accommodate. Survase et al (2011) found that similar continuous cultures of *C. acetobutylicum* produced mainly solvents at low dilution rates but mainly acids when the system is run at a high dilution rate.

This problem has occurred in industrial settings using continuous cultures of *C. acetobutylicum* in industrial settings and has been combated by using multi-stage continuous fermentation (Van der Merwe et al, 2013, Ni and Sun, 2009). The first stage of the multi-stage continuous fermentation allows for rapid growth and acid buildup as well as hydrogen production. The second stage has cells beginning to form spores and rapidly producing solvents. The final stage has cells that have reached the terminal stage of fermentation as the solventogenesis slows and cells begin to enter autolysis (Ni and Sun, 2009). The productivity of the immobilized cell system could similarly have been improved using a two-stage system.

Aside from the high acidity of the fermentation broth, a possible mutation occurred within the culture that caused the bacteria to prefer acetone production over 2-propanol production. While the cause of the change in metabolism is not fully known, the likely cause for the shift in solvent production may be caused by the low pH disrupting the secondary dehydrogenase activity responsible for the conversion of acetone to 2-propanol.

A slight elevation in ethanol production from the immobilized culture as compared to batch culture may be attributed to a small amount of yeast within the column. The microscopic images of the immobilized culture samples showed a small number of yeast cells among the *Clostridium beijerinckii optonii* cells in the medium. Though very few yeast cells were present, they may have contributed to the ethanol yield.

Bankar et al (2013) combined the use of two-stage immobilized cell culture with liquid-liquid extraction with oleyl alcohol to boost productivity. The highest overall productivity was

found using a dilution rate of 0.2 hr^{-1} where 13.6 g/L butanol and 20.3 g/L total solvents were produced.

The P2 medium used as vitamin and mineral supplementation in the immobilized culture was lacking calcium, a metal known to assist in surface adhesion (Alshiyab et al, 2008). The addition of CaCl to the immobilized culture may have increased the ability of the *Clostridium beijerinckii optonii* culture to form a biofilm within the column and thereby increase the number of cells used for fermentation. The increased number of cells could have increased the efficiency of the immobilized cell fermentation to improve the output of butanol.

Economics of Butanol Production

In order to make the commercial production of butanol economically feasible, one must maximize productivity while minimizing total costs. New advancements in genetic modifications allowed for the generation of the BA101 strain of *Clostridium beijerinckii*, which has the capability of producing butanol up to 19.7 g/L (Qureshi and Blaschek, 2000). Advancements in the use of cheaper substrates such as blackstrap molasses (Van der Merwe et al, 2013) enzymatically hydrolyzed biomass (Mariano and Filho, 2012) and replacement of vitamin and mineral supplements with cheaper supplements such as corn steep liquor (Qureshi and Blaschek, 2001) or vegetable mass (Survase et al, 2013) can help decrease the cost of fermentation. Advancements in fermentation techniques such as continuous fed batch fermentation or immobilized continuous fermentations help increase the productivity of butanol over time but sterilization of media can become problematic and costly (Van der Merwe et al, 2013).

Distilling butanol from water has a few problems when it comes to economically purifying butanol. Distillation of alcohols from aqueous broths typically form azeotropic

mixtures of water and alcohol (Vane, 2008). Furthermore, distillation of alcohol concentrations below 4% requires significantly greater energy. The azeotrope formed in the distillation of butanol at 101.3 kPa is 55.5% butanol. Since the solubility of butanol in water is limited to 7.7%, the azeotrope is formed in two phases. The top phase has a concentration of 79.9% butanol and the lower phase contains 7.7% butanol. Passing the top phase through a condenser column gives a 99.9% pure butanol. The lower phase is redistilled to further concentrate the butanol in the azeotropic mixture (Vane, 2008). The energy requirement for distillation of butanol is relatively high based on the maximum concentration of 1.3% butanol from fermentation. The heat of combustion of butanol is 36 MJ/kg, and the recommended energy required for separation of alcohols from liquids should not exceed one-third of the heat of combustion (Vane, 2008). As shown in Figure 54, a minimum concentration of 36 g/L butanol in the broth requires the 12 MJ/kg for distillation.

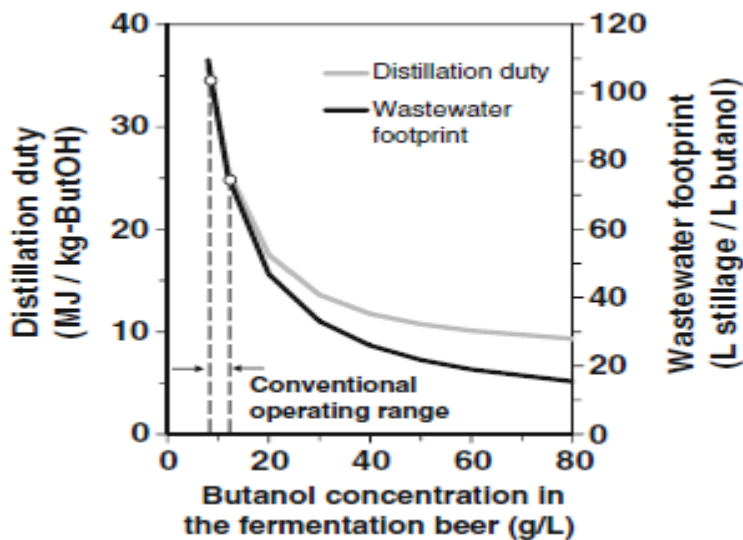

Figure 54 Energy requirement for complete dehydration of butanol and the wastewater generated (from Mariano et al, 2011)

The number of technologies available for separations of butanol from the fermentation broth have increased in recent years. New separation techniques include membrane separation, adsorption, gas stripping, liquid-liquid extraction (LLE) (Van der Merwe et al, 2013) and

pervaporation (Qureshi and Blaschek, 2000). Membrane separation shows high selectivity and low energy requirements but the membrane system is susceptible to clogging (Van der Merwe et al, 2013). Adsorption technology uses adsorbants such as silicate or ion-exchange resins to remove the butanol from the fermentation medium (Durre, 1998). Unfortunately, adsorption is susceptible to fouling and has low selectivity for butanol. Furthermore, the price of the adsorbents is relatively high and they often have a low capacity for retaining butanol. Gas stripping is similar to steam stripping distillation except it may be performed in-situ. Gas stripping is performed by purging the medium with gas and condensing the vapors (Durre, 1998). The advantages of gas stripping include relative ease of operation and low chances of clogging. The disadvantages of gas stripping are that it requires energy, there is a low selectivity for solvents and the solvents are not completely removed from the solution. By using a steady flow of N₂ gas through the fermentation medium into a gas stripping column kept at 4°C and a collection reservoir kept at 4°C, butanol production by *Clostridium beijerinckii* can be doubled while keeping the concentration of butanol in the fermentation broth below 3.5 g/L (Eziji et al, 2005). The flow of nitrogen caused excessive foaming which can be decreased by using antifoam. Unfortunately, the excessive antifoam used to decrease the foam inhibited the growth of *C. beijerinckii*. LLE shows high selectivity and can eliminate the need for a separation of the azeotropic mixture of butanol and water created in traditional steam stripping distillation (Van der Merwe et al, 2013). Pervaporation of butanol is done by using partial vaporization followed by permeation through a non-porous membrane before running through a condenser to concentrate the pervaporated butanol (Durre, 1998). Pervaporation provides a high selectivity and simplicity of performance, but unfortunately a large membrane area is required and the membrane runs a risk of clogging or fouling.

Each of the separation techniques requires energy. Steam stripping distillation requires 5,789 kcal/kg butanol, gas stripping requires 5,220 kcal/kg butanol, pervaporation requires 3,295 kcal/kg butanol and adsorption/desorption using silicalite requires 1,948 kcal/kg butanol (Qureshi et al, 2005). Along with the cost of the apparatuses for separation of butanol from fermentation broth, the energy requirements are part of the comprehensive measures to the cost of production of butanol. Butanol production will become more economical as technologies for fermentation and separation improve.

VI. SCIENTIFIC CONTRIBUTIONS

1. *Clostridium beijerinckii optonii* has a rare solvent profile. Few species of *C. beijerinckii* generate 2-propanol rather than acetone.
2. *C. beijerinckii optonii* shows a higher tolerance for 2-propanol than acetone. At concentrations of 2% by volume, acetone inhibits growth of *C. beijerinckii optonii* whereas growth is not inhibited by 2% 2-propanol.
3. *C. beijerinckii optonii* has a unique pH profile in that acidogenesis and solventogenesis occur concomitantly. Previous research implies that the start of solventogenesis terminates acidogenesis.
4. Sporulation and solventogenesis are not linked as previous research states. Solventogenesis can occur in the absence of sporulation.
5. Iron supplementation has little effect on the production of butanol by *C. beijerinckii optonii*.
6. The acid crash in the immobilized culture inhibits the secondary alcohol dehydrogenase enzyme resulting in increased acetone production and very little production of 2-propanol.
7. Low pH induces high stress for *C. beijerinckii optonii* and the cells become thin and elongated in order to increase the surface area to volume ratio.
8. While *C. beijerinckii optonii* is able to utilize sucrose as a food source, production of solvents is lower when the feedstock is primarily composed of sucrose rather than monosaccharides.
9. Continuous fermentation on an immobilized matrix eventually causes an acid crash which not only decreases the solvent production, but also changes the solvent ratios.

VII. FUTURE RESEARCH ADVICE

1. Test butanol production by *C. beijerinckii optonii* in the presence higher concentrations of $\text{FeSO}_4 \cdot 7\text{H}_2\text{O}$. The range of $1.8\mu\text{M}$ to $7.2\mu\text{M}$ may not have been large enough to show correlations between iron content and butanol production
2. Assemble a multi-stage continuous culture with pH control before broth enters the immobilized cell culture. This will help decrease the risk of acid crash, but may increase the risk of contamination.
3. Add calcium to the P2 mineral solution as calcium may help in the formation of biofilm.
4. Test sugarcane juice and molasses fermentations using invertase enzyme to increase the concentration of available monosaccharides.
5. Test whether or not autoclaving sugars and proteins separately can increase the production of butanol. Maillard browning products may have an inhibitory effect on *C. beijerinckii optonii* fermentation.

VIII. REFERENCES

- Adhami, L., Griggs, B., Himebrook, P., Taconi, K. 2009. "Liquid-Liquid Extraction of Butanol from Dilute Aqueous Solutions Using Soybean-Derived Biodiesel." *Journal of American Oil Chemists Society* 86:1123-1128.
- Ali, O.M., Mamat, R., Faizal, C.K.M. 2012. "Palm Biodiesel Production, Properties and Fuel Additives." *International Review of Mechanical Engineering* 6(7):1573-1580.
- Alsaker, K.V., Spitzer, T.R., Papoutsakis, E.T. 2004. "Transcriptional Analysis of *spo0A* Overexpression in *Clostridium acetobutylicum* and its Effect on the Cell's Response to Butanol Stress." *Journal of Bacteriology* 186(7):1959-1971.
- Alshiyab, H., Kalil, M.S., Hamid, A.A., Yusoff, W.M.W. 2008. "Trace Metal Effect on Hydrogen Production Using *C. acetobutylicum*." *Online Journal of Biological Sciences* 8(1)1-9.
- Al-Shorgani, N.K.N., Kalil, M.S., Yusoff, W.M.W. 2011. "The Effect of Different Carbon Sources on Biobutanol Production using *Clostridium saccharoperbutylacetonicum* N1-4." *Journal of Biotechnology* 10:280-285.
- Al-Shorgani, N.K.N., Hamid, A.A., Yusoff, W.M.W., Kalil, M.S. 2013. "Pre-Optimization of Medium of Biobutanol Production by a New Isolate of Solvent Producing *Clostridium*." *BioResources* 8(1):1420-1430.
- Bankar, S.B., Survase, S.A., Ojamo, H., Granstrom, T. 2013. "The Two Stage Immobilized Column Reactor with an Integrated Solvent Recovery Module for Enhanced ABE Production." *Bioresour Technol* 140:269-276.
- Barzegar, R., Shafee, S., Khalilarya, S. 2013. "Computational Fluid Dynamics Simulation of the Combustion Process, Emission Formation and the Flow Field in an Indirect Injection Diesel Engine." *Thermal Science* 17(1):11-23.
- Basset, G.J.C., Quinlivan, E.P., Ravel, S., Rebielle, F., Nichols, B.P., Shinozaki, K., Seki, M., Adams-Phillips, L.C., Giovannoni, J.J., Gregory III, J.F., Hanson, A.D. 2004. "Folate Synthesis in Plants: the p-Aminobenzoate Branch is Initiated by a Bifunctional PabA-PabB Protein that is Targeted to Plastids." *Proceedings of the National Academy of Sciences of the United States of America* 101(6):1496-1501.
- Beesch, S.C. 1952. "Acetone-Butanol Fermentation of Starches." *Industrial and Engineering Chemistry* 44(7):1677.
- Black, J.G. "Growth and Culturing of Bacteria." *Microbiology Principles and Explorations*. Hoboken, NJ: Wiley & Sons, 2004. 142-171.
- Black, J.G. "Essential Concepts of Metabolism." *Microbiology Principles and Explorations*. Hoboken, NJ: Wiley & Sons, 2004. 112-141.

Blumberg, P.N., Bromberg, L., Kang, H., Tai, C. 2008. "Simulation of High Efficiency Heavy Duty SI Engines Using Direct Injection of Alcohol for Knock Avoidance." *SAE Powertrains, Fuel and Lubricants Meeting, Massachusetts Institute of Technology.*

BP Statistical Review of World Energy. 2012.

http://www.bp.com/assets/bp_internet/globalbp/globalbp_uk_english/reports_and_publications/statistical_energy_review_2011/STAGING/local_assets/pdf/statistical_review_of_world_energy_full_report_2012.pdf

Canacki, M., Ozsezen, A.N., Alptekin, E., Eyidogan, M. 2013. "Impact of Alcohol-Gasoline Fuel Blends on the Exhaust Emission of an SI Engine." *Renewable Energy* 52:111-117.

Chen, Y., Zhou, T., Liu, D., Li, A., Xu, S., Liu, Q., Li, B., Ying, H. 2013. "Production of Butanol from Glucose and Xylose with Immobilized Cells of *Clostridium acetobutylicum*." *Biotechnology and Bioprocess Engineering* 18:234-241.

Chen, C.K., Blaschek, H.P. 1999. "Acetate Enhances Solvent Production and Prevents Degeneration in *Clostridium beijerinckii* BA101." *Applied Microbiology and Biochemistry* 52:170-173.

Cohn, D.R., Bromberg, L., Heywood, J.B. 2005. "Direct Injection Ethanol Boosted Gasoline Engines: Biofuel Leveraging for Cost-Effective Reduction of Oil Dependence and CO₂ Emissions." *LFEE Publication 2005-1*, Massachusetts Institute of Technology.

Dai, Z., Dong, H., Zhu, Y., Zhang, Y., Li, Y., Ma, Y. 2012. "Introducing a Single Secondary Alcohol Dehydrogenase into Butanol Tolerant *Clostridium acetobutylicum* Rh8 Switches ABE Fermentation to High Level IBE Fermentation." *Biotechnology for Biofuels* 5:44-53.

Dhamole, P.B., Wang, Z., Liu, Y., Wang, B., Feng, H. 2012. "Extractive Fermentation with Non-Ionic Surfactants to Enhance Butanol Production." *Biomass and Bioenergy* 40:112-119.

Durre, P. 1998. "New Insights and Novel Developments in Clostridial Acetone/Butanol/Isopropanol Fermentation." *Applied Microbiology and Biotechnology* 49:639-648.

Durre, P. 2008. "Fermentative Butanol Production Bulk Chemical and Biofuel." *Annals of the New York Academy of Sciences* 1125:353-362.

Environmental Protection Agency. 1998. "1-Butanol Facts Sheet." http://www.epa.gov/chemfact/s_butano.txt

Evans, P.J., Wang, H.Y. 1988. "Enhancement of Butanol Formation by *Clostridium acetobutylicum* in the Presence of Decanol-Oleyl Alcohol Mixed Extractants." *Applied and Environmental Microbiology* July:1662-1667.

- Eziji, T., Karcher, P.M., Qureshi, N., Blaschek, H.P. 2005. "Improving Performance of a Gas Stripping-Based Recovery System to Remove Butanol from *Clostridium beijerinckii* Fermentation." *Bioprocess and Biosystems Engineering* 27:207-214.
- Ezeji, T., Qureshi, N., Blaschek, H.P. 2007. "Butanol Production from Agricultural Residues: Impact of Degradation Products on *Clostridium beijerinckii* Growth and Butanol Fermentation." *Biotechnology and Bioengineering* 97(6):1460-1469.
- Gheshlaghi, R., Scharer, J.M., Moo-Young, M., Chou, C.P. 2009. "Metabolic Pathways of Clostridia for Producing Butanol." *Biotechnology Advances* 27:764-781.
- Guerrini, O., Burlat, B., Leger, C., Guigliarelli, B., Soucaille, P., Girbal, L. 2008. "Characterization of Two 2[4Fe4S] Ferredoxins from *Clostridium acetobutylicum*." *Current Microbiology* 56:261-267.
- Guo, T., Tang, Y., Xi, Y.L., He, A.Y., Sun, B.J., Wu, H., Liang, D.F., Jiang, M., Ouyang, P.K. 2011. "*Clostridium beijerinckii* Mutant Obtained by Atmospheric Pressure Glow Discharge Producing High Proportions of Butanol and Solvent Yields." *Biotechnology Letters* 33:2379-2383.
- Hanai, T., Atsumi, S., Liao, J.C. 2007. "Engineered Synthetic Pathway for Isopropanol Production in *Escherichia coli*." *Applied Environmental Microbiology* 73(24):7814-7818.
- Hoskisson, P.A., Hobbs, G. 2005. "Continuous Culture – Making a Comeback?" *Microbiology* 151(10):3153-3159.
- Housewright, R.D., Koser, S.A. 1944. "A Study of Para-Aminobenzoic Acid Requirement of *Clostridium acetobutylicum* Application to Assay Procedure." *The Journal of Infectious Diseases* 75(2):113-126.
- Jackson, W.R., Macek, T.J. 1944. "B Complex Vitamins in Sugar Cane and Sugar Cane Juice." *Industrial Engineering and Chemistry* 36(3):261-263.
- Johnson, J.L., Toth, J., Santiwatanakul, S., Chen, J.S. 1997. "Cultures of *Clostridium acetobutylicum* from various collections comprise *Clostridium acetobutylicum*, *Clostridium beijerinckii*, and two other distinct types based on DNA-DNA reassociation." *International Journal of Systematic Bacteriology* 47:420-424.
- Jones, D.T., Woods, D.R. 1986. "Acetone-Butanol Fermentation Revisited." *Microbiological Reviews* December:484-524.
- Keis, S., Bennett, C.F., Ward, V.K., Jones, D.T. 1995. "Taxonomy and Phylogeny of Industrial Solvent-Producing Clostridia." *International Journal of Systematic Bacteriology* 45(4):693-705.
- Keis, S., Shaheen, R., Jones, D.T. 2001. "Emended descriptions of *Clostridium acetobutylicum* and *Clostridium beijerinckii*, and descriptions of *Clostridium*

saccharoperbutylaceticum sp. nov. and *Clostridium saccharobutylicum* sp. nov.”
International Journal of Systematic and Evolutionary Microbiology 51:2095-2103.

Keskin, T., Giusti, L., Azbar, N. 2012. “Continuous Biohydrogen Production in Immobilized Biofilm System Versus Suspended Cell Culture.” *International Journal of Hydrogen Energy* 37:1418-1424.

Kletzin, A., Adams, M.W.W. 1996. “Molecular and Phylogenetic Characterization of Pyruvate and 2-Ketoisovalerate Ferredoxin Oxidoreductases from *Pyrococcus furiosus* and Pyruvate Ferredoxin Oxidoreductase from *Thermotoga maritime*.” *Journal of Bacteriology* Jan:248-257.

Kress, D., Brugel, D., Schall, I., Linder, D., Buckel, W., Essen, L.O. 2009. “An Asymmetric Model for Na⁺-Translocating Glutaconyl-CoA Decarboxylases.” *Journal of Biological Chemistry* 284(41):28401-28409.

Kuit, W., Minton, N.P., Lopez-Contreras, A.M., Eggink, G. 2012. “Disruption of the Acetate Kinase (*ack*) Gene of *Clostridium acetobutylicum* Results in Delayed Acetate Production.” *Applied Microbiology and Biotechnology* 94:729-741.

Lee, S.M., Cho, M.O., Park, C.H., Chung, Y.C., Kim, J.H., Sang, B.I., Um, Y. 2008. “Continuous Butanol Production Using Suspended and Immobilized *Clostridium beijerinckii* NCIMB 8052 with Supplementary Butyrate.” *Energy and Fuels* 22:3459-3464.

Lehman, D., Lutke-Eversloh, T. 2011. “Switching *Clostridium acetobutylicum* to an Ethanol Producer by Disruption of the Butyrate/Butanol Fermentative Pathway.” *Metabolic Engineering* 13:464-473.

Lehmann, D., Honicke, D., Ehrenreich, A., Schmidt, M., Weuster-Botz, D., Bahl, H., Lutke-Eversloh, T. 2012. “Modifying the Product Pattern of *Clostridium acetobutylicum*: Physiological Effects of Disrupting the Acetate and Acetone Formation Pathways.” *Applied Microbiology and Biotechnology* 94:743-754.

Lehmann, D., Radmonski, N., Lutke-Eversloh, T. 2012. “New Insights into the Butyric Acid Metabolism of *Clostridium acetobutylicum*.” *Applied Microbiology and Biotechnology* 96:1325-1339.

Lin, Y.L., Blaschek, H.P. 1983. “Butanol Production by a Butanol-Tolerant Strain of *Clostridium acetobutylicum* in Extruded Corn Broth.” *Applied and Environmental Microbiology* 45(3):966-973.

Maddox, I.S., Steiner, E., Hirsch, S., Wessner, S., Gutierrez, N.A., Gapes, J.R., Schuster, K.C. 2000. “The Cause of ‘Acid Crash’ and ‘Acidogenic Fermentations’ During the Batch Acetone-Butanol-Ethanol (ABE) Fermentation Process.” *Journal of Molecular Microbiology and Biotechnology* 2(1):95-100.

- Mariano, A.P., Filho, R.M. 2012. "Improvements in Biobutanol Fermentation and Their Impacts on Distillation Energy Consumption and Wastewater Generation." *Bioenergy Resources* 5:504-514.
- Mariano, A.P., Keshtkar, M.J., Atala, D.I.P., Filho, F.M., Maciel, M.R.W., Filho, R.M., Stuart, P. 2011. "Energy Requirements for Butanol Recovery Using the Flash Fermentation Technology." *Energy and Fuel* 25:2347-2355.
- Mariano, A.P., Qureshi, N., Filho, R.M., Eziji, T.C. 2011. "Assessment of *In-Situ* Butanol Recovery by Vacuum During Acetone Butanol Ethanol (ABE) Fermentation." *Journal of Chemical Technology and Biotechnology* 87:334-340.
- Marulanda, V.F. 2012. "Biodiesel Production by Supercritical Methanol Transesterification: Process Simulation and Potential Environmental Impact Assessment." *Journal of Cleaner Production* 33:109-116.
- Nair, R.V., Green, E.M., Watson, D.E., Bennett, G.N., Papoutsakis, E.T. 1999. "Regulation of the *sol* Locus Genes for Butanol and Acetone Formation in *Clostridium acetobutylicum* ATCC 824 by a Putative Transcriptional Repressor." *Journal of Bacteriology* 181:319-330.
- Napoli, F., Olivieri, G., Russo, M.E., Marzocchella, A., Salatino, P. 2010. "Butanol Production by *Clostridium acetobutylicum* in a Continuous Packed Bed Reactor." *Journal of Industrial Microbiology and Biotechnology* 37:603-608.
- Ni, Y., Sun, Z. 2009. "Recent Progress on Industrial Fermentative Production of Acetone-Butanol-Ethanol by *Clostridium acetobutylicum* in China." *Applied Microbiology and Biotechnology* 83:415-423.
- Ni, Y., Wang, Y., Sun, Z. 2012. "Butanol Production from Cane Molasses by *Clostridium saccharobutylicum* DSM 13864: Batch and Semicontinuous Fermentation." *Applied Biochemistry and Biotechnology* 166:1896-1907.
- Parekh, M., Formanek, J., Blaschek, H.P. 1998. "Development of a Cost-Effective Glucose Corn-Steep Medium for Production of Butanol by *Clostridium beijerinckii*." *Journal of Industrial Microbiology and Biotechnology* 21:187-191.
- Patakova, P., Linhova, M., Rychtera, M., Paulova, L., Melzoch, K. 2013. "Novel and Neglected Issues of Acetone-Butanol-Ethanol (ABE) Fermentation by Clostridia: *Clostridium* Metabolic Diversity, Tools for Process Mapping and Continuous Fermentation Systems." *Biotechnology Advances* 31:58-67.
- Pattanaik, B.P., Nayak, C., Nanda, B.K. 2013. "Investigation on Utilization of Biogas and Karanja Oil Biodiesel in Dual Fuel Mode in a Single Cylinder DI Diesel Engine." *Energy and Environment* 4(2):279-290.

- Qureshi, N., Blaschek, H.P. 1999. "Butanol Recovery from Model Solutions/Fermentation Broth by Pervaporation: Evaluation of Membrane Performance." *Biomass Bioenergy* 17:175–184.
- Qureshi, N., Blaschek, H.P. 2000. "Butanol Production using *Clostridium beijerinckii* BA101 Hyper-Butanol Producing Mutant Strain and Recovery by Pervaporation." *Applied Biochemistry and Biotechnology* 84-86:225-235.
- Qureshi, N., Blaschek, H.P. 2001. "Evaluation of Recent Advances in Butanol Fermentation, Upstream and Downstream Processing." *Bioprocess and Biosystems Engineering* 24:219-226.
- Qureshi, N., Hughes, S., Maddox, I.S., Cotta, M.A. 2005. "Energy-Efficient Recovery of Butanol from Model Solutions and Fermentation Broth by Adsorption." *Bioprocess and Biosystems Engineering* 27:215-222.
- Qureshi, N., A. Lolas and H.P. Blaschek, 2001. "Soy Molasses as Fermentation Substrate for Production of Butanol using *Clostridium beijerinckii* BA 101." *Journal of Industrial Microbiology and Technology* 26:290-295.
- Ramey, D. 2007. "Butanol: the Other Alternative Fuel." *Agricultural Biofuels: Technology, Sustainability and Profitability* 137-147.
http://nabc.cals.cornell.edu/pubs/nabc_19/NABC19_5Plenary2_Ramey.pdf
- Rattanapan, A., Limtong, S., Phisalaphong, M. 2011. "Ethanol Production by Repeated Batch and Continuous Fermentations of Blackstrap Molasses Using Immobilized Yeast Cells on Thin-Shell Silk Cocoons." *Applied Energy* 88:4400-4404.
- Ravagnani, A., Jennert, K.C.B., Steiner, E., Grunger, R., Jeffries, J.R., Wilkinson, S.R., Young, D.I., Tidswell, E.C., Brown, D.P., Youngman, P., Morris, J.G., Young, M. 2000. "Spo0A Directly Controls the Switch from Acid to Solvent Production in Solvent-Forming Clostridia." *Molecular Biology* 37(5):1172-1185.
- Richter, H., Qureshi, N., Heger, S., Dien, B., Cotta, M.A., Angenent, L.T. 2011. "Prolonged Conversion of n-Butyrate to n-Butanol with *Clostridium saccharoperbutylacetonicum* in a Two-Stage Continuous Culture with In-Situ Product Removal." *Biotechnology and Bioengineering* 109(4):913-921.
- Roussan, D.A., Shaheen, I.A., Totanji, W.S., Khawaldeh, G.Y., Al Rifai, R.H. 2012. "Simultaneous Detection of *Clostridium perfringens* and *Clostridium colinum* by Duplex-Polymerase Chain Reaction." *Poultry Science* 91(12):3080-3085.
- Shaheen, R., Shirley, M., Jones, D.T. 2000. "Comparative Fermentation Studies of Industrial Strains Belonging to Four Species of Solvent-Producing Clostridia." *Journal of Molecular Microbiology and Biotechnology* 2(1):115-124.

- Shen, C.R., Lan, E.I., Dekishima, Y., Baez, A., Cho, K.M., Liao, J.C. 2011. "Driving Forces Enable High-Titer Anaerobic 1-Butanol Synthesis in *Escherichia coli*." *Applied Environmental Microbiology* 77:2905-2915.
- Shu, Q., Zhang, Q., Xu, G., Nawaz, Z., Wang, D., Wang, J. 2009. "Synthesis of Biodiesel from Cottonseed Oil and Methanol Using Carbon-Based Solid Acid Catalyst." *Fuel Processing Technology* 90:1002-1008.
- Sillers, R., Chow, A., Tracy, B., Papoutsakis, E.T. 2008. "Metabolic Engineering of the Non-Sporulating, Non-Solventogenic *Clostridium acetobutylicum* Strain M5 to Produce Butanol without Acetone Demonstrate the Robustness of the Acid-Formation Pathways and the Importance of the Electron Balance." *Metabolic Engineering* 10:321-332.
- Sneath, P.H.A, Mair, N.S., Sharpe, M.E., Holt, J.G. "Genus *Clostridium*." *Bergey's Manual of Systematic Bacteriology*. Baltimore, MD: Williams and Wilkins, 1986. 1141-1200. Print.
- Survase, S.A., Jurgens, G., Van Heiningen, A., Granstrom, T. 2011. "Continuous Production of Isopropanol and Butanol using *Clostridium beijerinckii* DSM 6423." *Applications in Microbiology and Technology* 91:1305-1313.
- Survase, S.A., VanHeiningen, A., Granstrom, T. 2013. "Wood Pulp as an Immobilization Matrix for the Continuous Production of Isopropanol and Butanol." *Journal of Industrial Microbiology and Biotechnology* 40:209-215.
- Survase, S.A., Sklavounos, E., Van Heiningen, A., Granstrom, T. 2013. "Market Refused Vegetables as a Supplement for Improved Acetone-Butanol-Ethanol Production by *Clostridium acetobutylicum* DSM 792." *Industrial Crops and Products* 45:349-354.
- Szulczyk, K.R. 2010. "Which is a Better Transportation Fuel – Butanol or Ethanol?" *International Journal of Energy and Environment* 1(3):501-512.
- Thang, V.H., Kanda, K., Kobayashi, G. 2010. "Production of Acetone-Butanol-Ethanol (ABE) in Direct Fermentation of Cassava by *Clostridium saccharoperbutylacetonicum* N1-4." *Applied Biochemistry and Biotechnology* 161:157-170.
- Thompson, J., Hess, S., Pikiš, A. 2004. "Genes *malh* and *pagl* of *Clostridium acetobutylicum* ATCC 824 Encode NAD⁺ and Mn²⁺-Dependent Phospho- α -glucosidase(s)." *Journal of Biological Chemistry* 279(2):1553-1561.
- Tomic, M.D., Savin, L.D., Micic, R.D., Simikic, M.D., Furman, T.F. 2013. "Effect of Fossil Diesel and Biodiesel Blends on the Performances and Emissions of Agricultural Tractor Engines." *Thermal Science* 17(1):263-278.
- United States Department of Agriculture. 2009. "Advancing Renewable Energy and Energy Efficiency at USDA."

- Van der Merwe, A.B., Cheng, H., Gorgens, J.F., Knoetze, J.H. 2013. "Comparison of Energy Efficiency and Economics of Process Designs for Biobutanol Production from Sugarcane Molasses." *Fuel* 105:451-458.
- Vane, L.M. 2008. "Separation Technologies for the Recovery and Dehydration of Alcohols from Fermentation Broths." *Biofuels, Bioproducts and Biorefineries* 2:553-588.
- Vasileva, D., Janssen, H., Honicke, D., Ehrenreich, A., Bahl, H. 2012. "Effect of Iron Limitation and *fur* Gene Inactivation on the Transcriptional Profile of the Strict Anaerobe *Clostridium acetobutylicum*." *Microbiology* 158:1918-1929.
- Ventura, J.R.S., Hu, H., Jahng, D. 2013. "Enhanced Butanol Production in *Clostridium acetobutylicum* ATCC 824 by Double Overexpression of 6-Phosphofructokinase and Pyruvate Kinase Genes." *Applied Microbiology and Biotechnology* 97:7505-7516.
- Waheed, S., Ahmad, S. 2008. "Instrumental Neutron Activation Analysis of Different Products from the Sugarcane Industry in Pakistan: Essential Elements for Nutritional Adequacy." *Journal of AOAC International* 91(2):392-399.
- Wallner, T., Ickes, A., Lawyer, K. 2012. "Analytical Assessment of C2-C8 Alcohols as Spark-Ignition Engine Fuels." *Proceedings of the FISITA 2012 World Automotive Congress* 3:15-26.
- Wang, S., Zhang, Y., Dong, H., Mao, S., Zhu, Y., Wang, R., Luan, G., Li, Y. 2011. "Formic Acid Triggers the "Acid Crash" of Acetone-Butanol-Ethanol Fermentation by *Clostridium acetobutylicum*." *Applied and Environmental Microbiology* Mar:1674-1680.
- Wang, S., Zhu, Y., Zhang, Y., Li, Y. 2012. "Controlling the Oxidoreductase Potential of the Culture of *Clostridium acetobutylicum* Leads to an Earlier Initiation of Solventogenesis, Thus Increasing Solvent Productivity." *Applied Microbiology and Biotechnology* 93:1021-1030.
- Wiser, R., Namovicz, C., Gielecki, M., Smith, R. 2007. "Renewable Portfolio Standards: A Factual Introduction to Experience from the United States." *Electricity Journal* 20(4):8-20.
- Wolfe, R.S., O'Kane, D.J. 1953. "Cofactors for the Phosphoroclastic Reaction of *Clostridium acetobutylicum*." *Journal of Biological Chemistry* 205:755-765.
- Zheng, Y.N., Li, L.Z., Xian, M., Ma, Y.J., Yang, J.M., Xu, X., He, D.Z. 2009. "Problems with the Microbial Production of Butanol." *Journal of Industrial Microbiology and Biotechnology* 36:1127-1138.
- Zhu, L., Dong, H., Zhang, Y., Li, Y. 2011. "Engineering the Robustness of *Clostridium acetobutylicum* by Introducing Glutathione Biosynthetic Capability." *Metabolic Engineering* 13(4):426-434.
- Zhuang, Y., Hong, G. 2013. "Primary Investigation to Leveraging Effect of Using Ethanol Fuel on Reducing Gasoline Fuel Consumption." *Fuel* 105:425-431.

IX. VITA

Adam Hoogewind is a native of Muskegon, Michigan. After graduating from Fruitport High School in 2002, he attended Aquinas College in Grand Rapids, Michigan where he earned his Bachelor's Degree with majors in Chemistry and Biology in 2006. He worked in quality assurance at Amway in Ada, Michigan and Elan Nutrition (currently ConAgra) in Grand Rapids, Michigan and quality assurance management at The Mushroom Company in Cambridge, Maryland before pursuing his doctorate in the Department of Nutrition and Food Sciences at Louisiana State University. While in Baton Rouge, Adam worked as a personal trainer at Bally Total Fitness. Upon completion of his doctorate, Adam plans to work in quality assurance or research and development management at a food manufacturing facility.